

REV			
DATE			
BY			
DESCRIPTION			

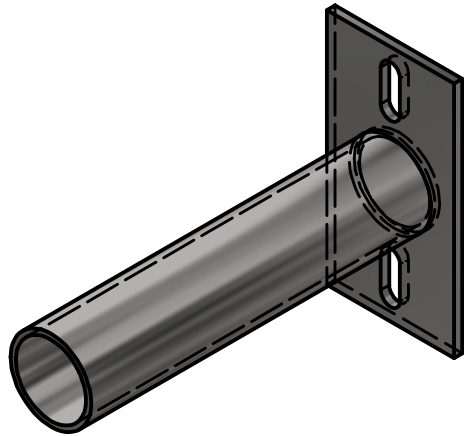

2 3/8" O.D. x .154 WALL TB.

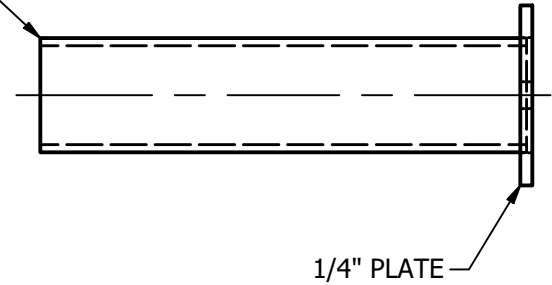

1/4" PLATE

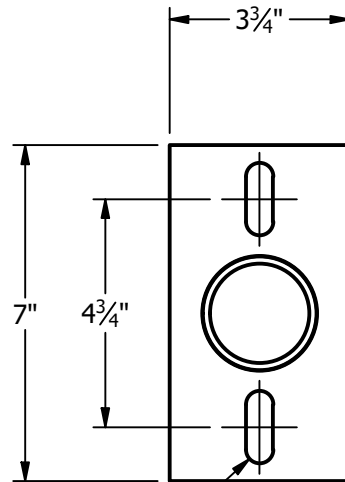

.562 x 1.50 SLOT
(2 PLCS.)

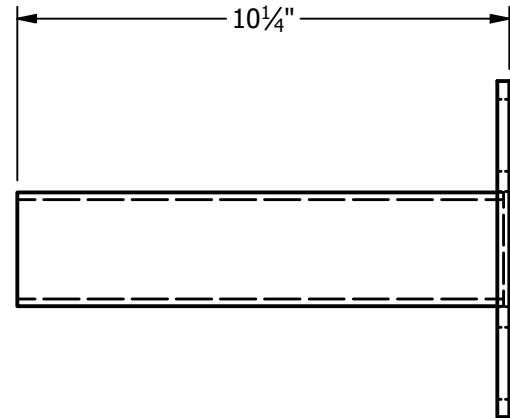

TOTAL WT. = 4.494 lbmass

THIS DOCUMENT CONTAINS PROPRIETARY INFORMATION. DUPLICATION OR DISCLOSURE IS PROHIBITED WITHOUT THE EXPRESSED WRITTEN CONSENT OF FABRICATED METALS LLC	TOLERANCES: UNLESS OTHERWISE SPECIFIED		DRAWN BY: P. DAUGHERTY
	FRACTIONAL	±1/8"	APPROVED: PD
	2 PLACE DEC.	±.03	ECN:
	3 PLACE DEC.	±.005	SCALE: 1/4" = 1"
	ANGULAR	± 1°	DATE: 3/16/2018

UTILITY METALS (A DIVISION OF FABRICATED METALS LLC.)	
DESCRIPTION:	
2" x 10" SIDE TENON	

PART NO. ST-2-10 BKT000102	
DWG NO. F-8124-0	REV 0