

2 3/8" O.D. x .154 WALL TB,

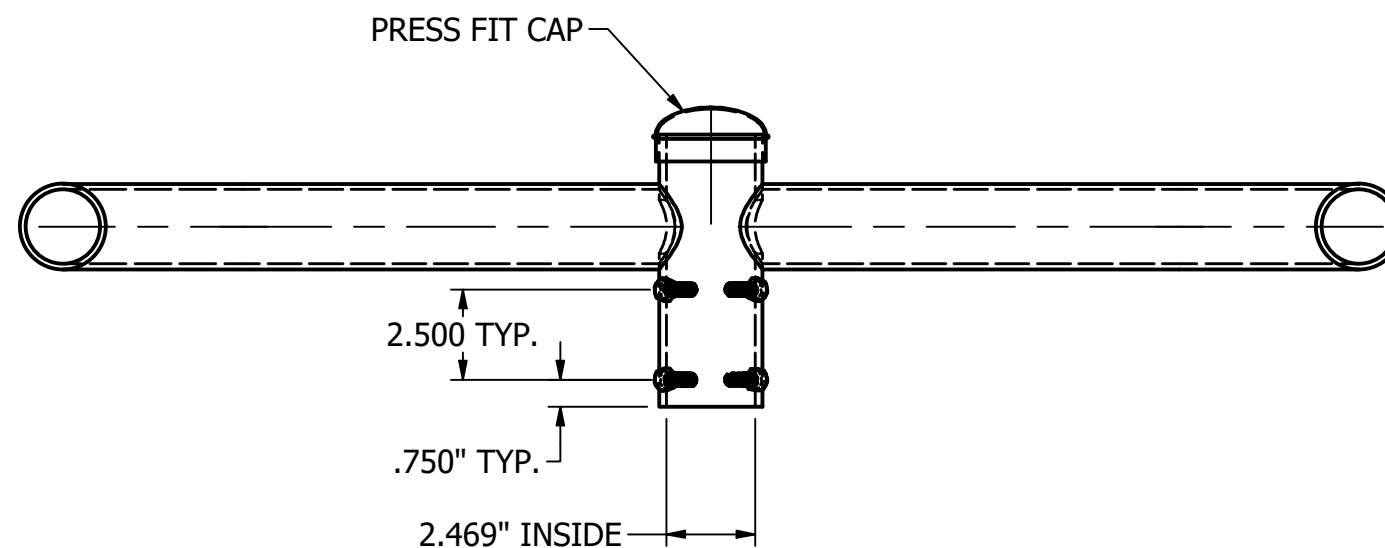
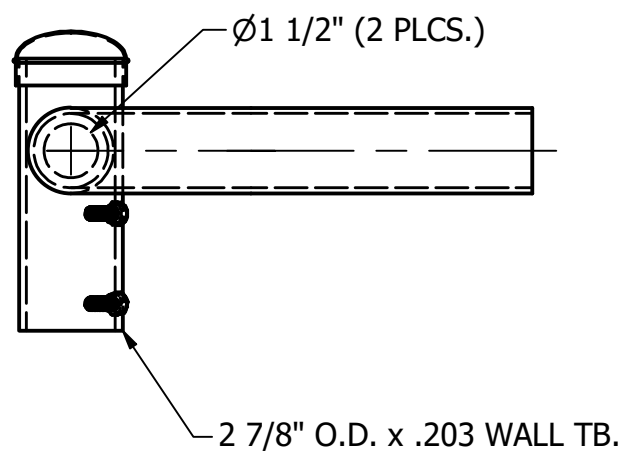

TOTAL WT. = 20.418 lbmass

				THIS DOCUMENT CONTAINS PROPRIETARY INFORMATION. DUPLICATION OR DISCLOSURE IS PROHIBITED WITHOUT THE EXPRESSED WRITTEN CONSENT OF FABRICATED METALS LLC	TOLERANCES: UNLESS OTHERWISE SPECIFIED FRACTIONAL ±1/8" 2 PLACE DEC. ±.03 3 PLACE DEC. ±.005 ANGULAR ±1°	DRAWN BY: P. DAUGHERTY	UTILITY METALS (A DIVISION OF FABRICATED METALS LLC.) DESCRIPTION: 2 LIGHT 36" HORIZONTAL BULLHORN BRACKET TO SLIP 2 3/8" TENON	PART NO. HS2-S36-2	
						APPROVED: PD		DWG NO. G-9343-0	
						ECN:		REV 0	
						SCALE: 3/16" = 1" DATE: 8/31/2020			
REV	DATE	BY	DESCRIPTION						