

2 3/8" O.D. x .154 WALL TB.

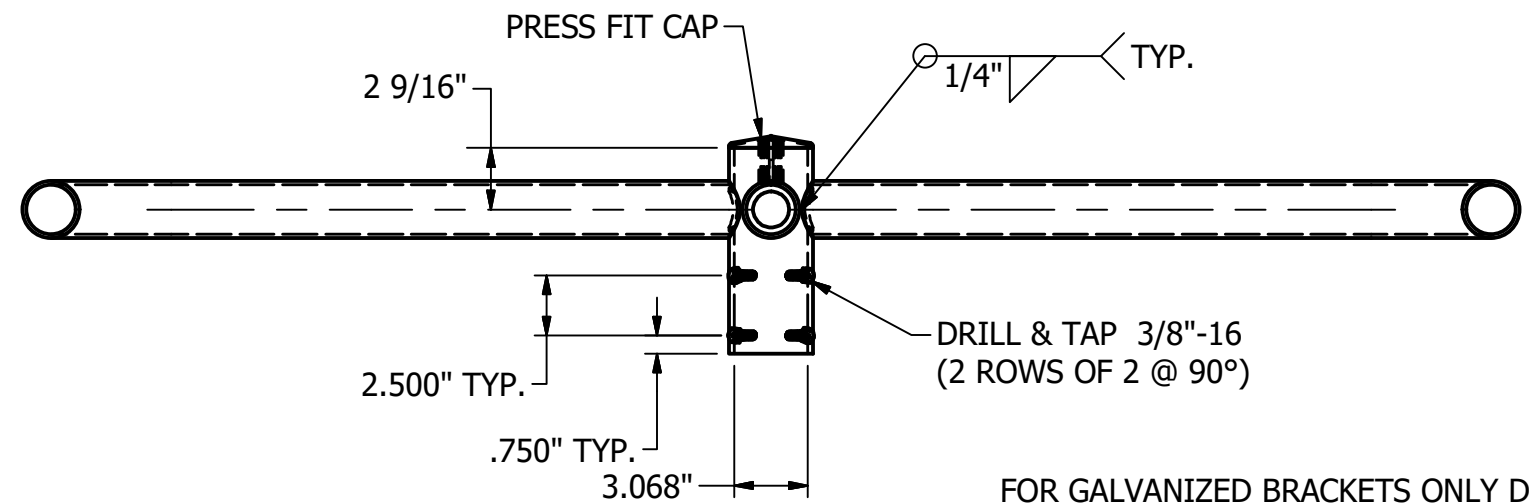
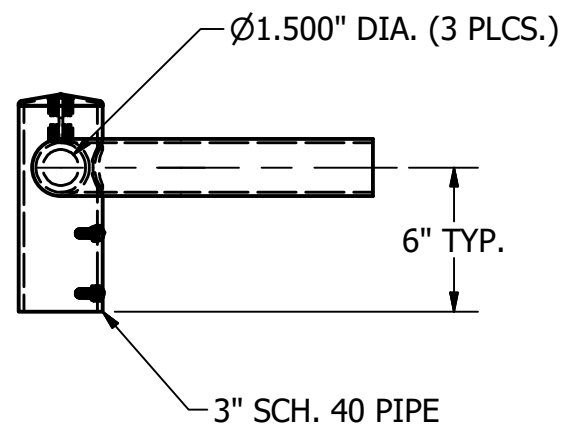
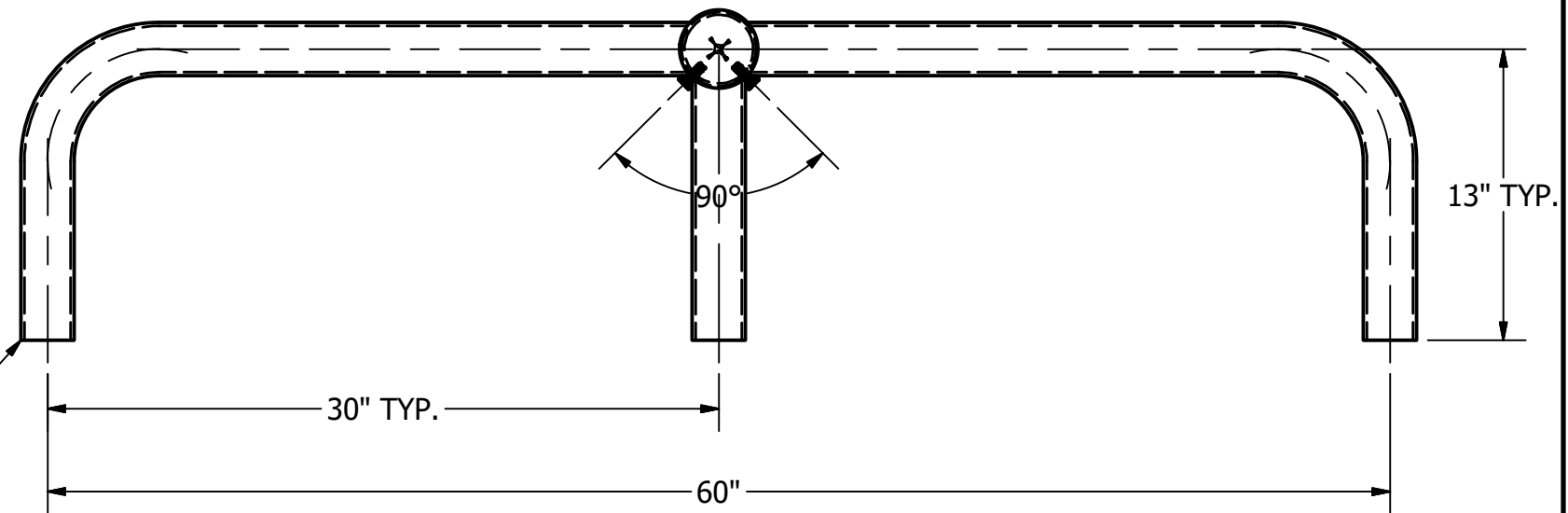

DRILL & TAP 3/8"-16  
(2 ROWS OF 2 @ 90°)

FOR GALVANIZED BRACKETS ONLY DRILL & TAP 3/8"-16 .010 OVERSIZED TAP.

TOTAL WT. = 32.708 lbmass

			THIS DOCUMENT CONTAINS PROPRIETARY INFORMATION. DUPLICATION OR DISCLOSURE IS PROHIBITED WITHOUT THE EXPRESSED WRITTEN CONSENT OF FABRICATED METALS LLC	TOLERANCES: UNLESS OTHERWISE SPECIFIED FRACTIONAL ±1/8" 2 PLACE DEC. ±.03 3 PLACE DEC. ±.005 ANGULAR ±1°	DRAWN BY: P. DAUGHERTY	<b>UTILITY METALS</b> (A DIVISION OF FABRICATED METALS LLC.) DESCRIPTION: 3 LIGHT 30" HORIZONTAL BULLHORN BRACKET TO SLIP 2 7/8" O.D. TENON	PART NO. HS3-S30-3	
					APPROVED: PD		DWG NO. G-9350-0	
					ECN:		REV 0	
REV	DATE	BY			DESCRIPTION		SCALE: 1/8" = 1"	DATE: 9/1/2020