

2 3/8" O.D. x .154 WALL TB.

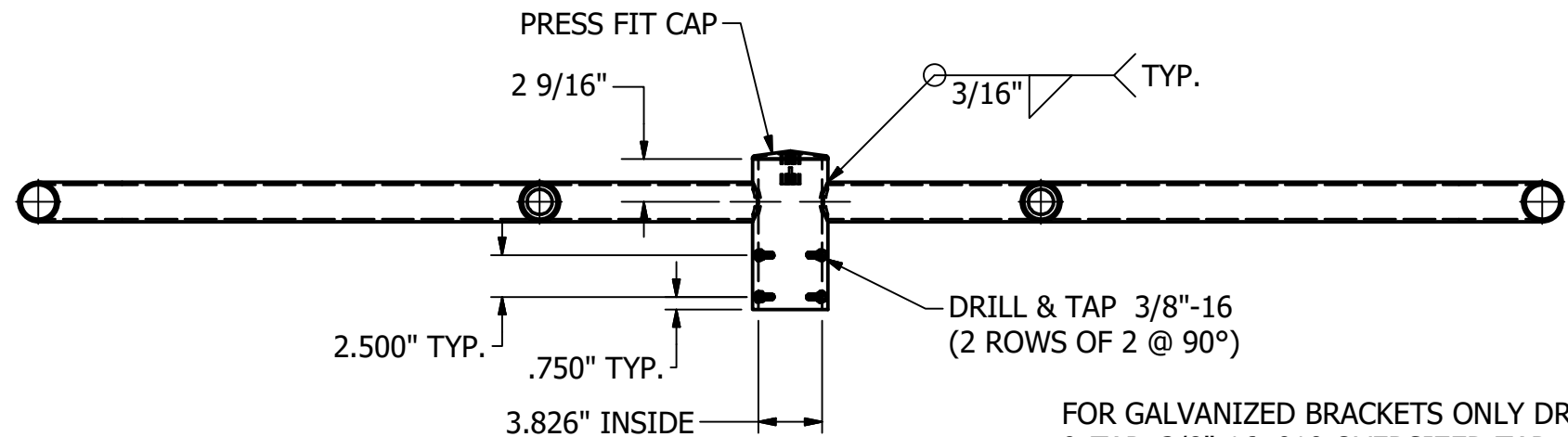
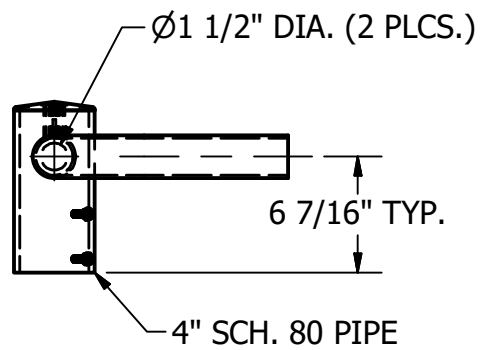
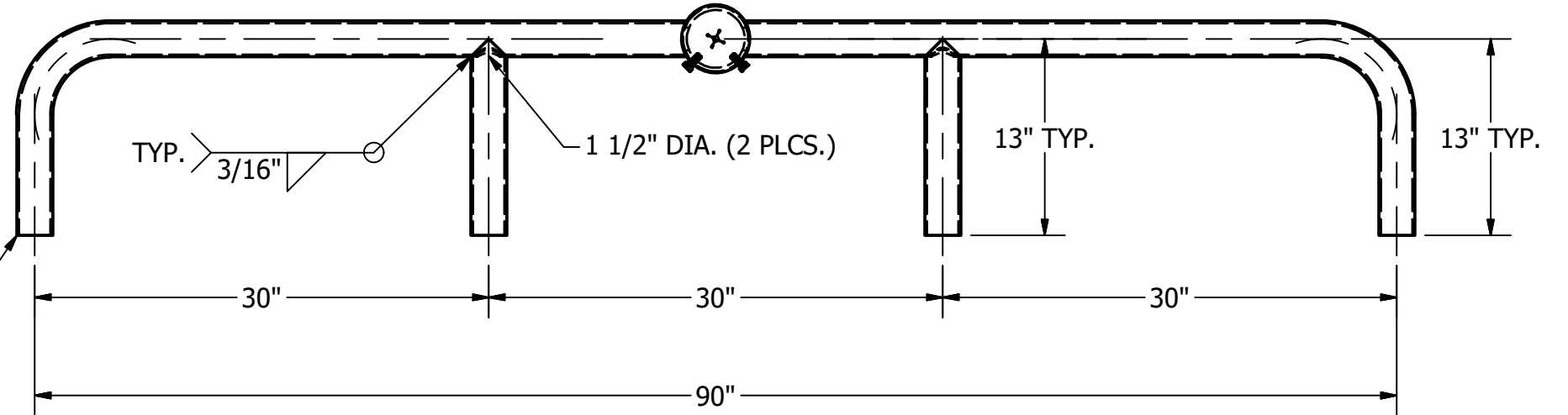

FOR GALVANIZED BRACKETS ONLY DRILL & TAP 3/8"-16 .010 OVERSIZED TAP.

TOTAL WT. = 51.106 lbmass

REV	DATE	BY	DESCRIPTION	THIS DOCUMENT CONTAINS PROPRIETARY INFORMATION. DUPLICATION OR DISCLOSURE IS PROHIBITED WITHOUT THE EXPRESSED WRITTEN CONSENT OF FABRICATED METALS LLC	TOLERANCES: UNLESS OTHERWISE SPECIFIED FRACTIONAL ±1/8" 2 PLACE DEC. ±.03 3 PLACE DEC. ±.005 ANGULAR ±1°	DRAWN BY: P. DAUGHERTY APPROVED: PD ECN: SCALE: 3/32" = 1" DATE: 9/8/2020	UTILITY METALS (A DIVISION OF FABRICATED METALS LLC.) DESCRIPTION: 4 LIGHT 30" HORIZONTAL BULLHORN BRACKET TO SLIP 3 1/2" TENON	PART NO. HS4-S30-3.5	DWG NO. G-9358-0	REV 0