

2 3/8" O.D. x .154 WALL TB.

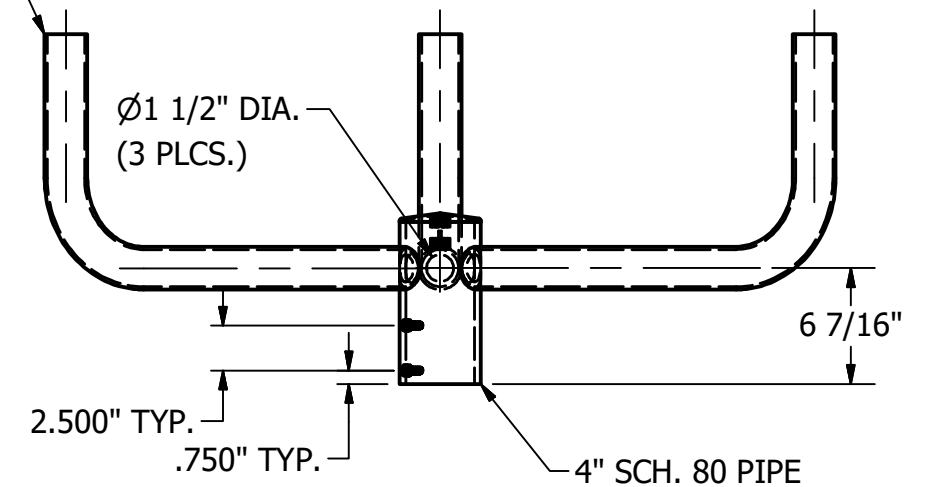
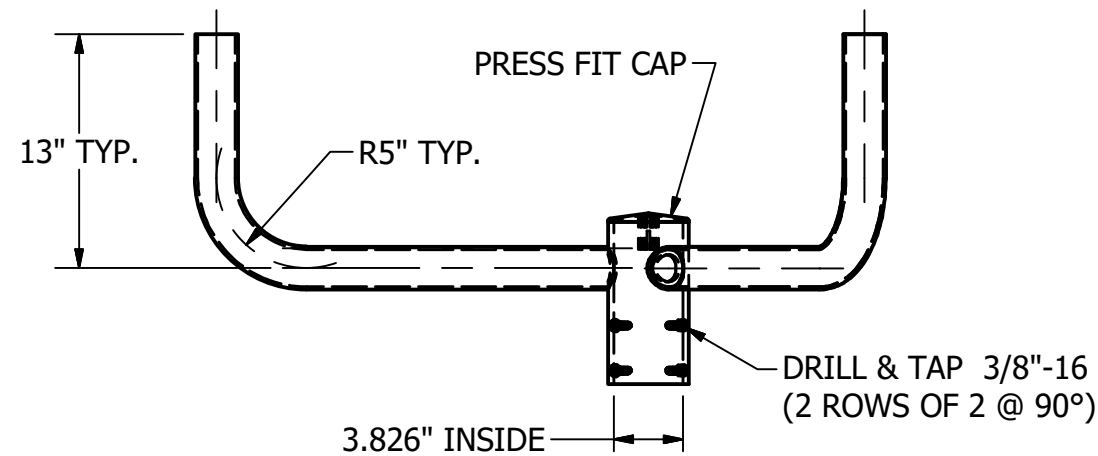

FOR GALVANIZED BRACKETS ONLY DRILL & TAP 3/8"-16 .010 OVERSIZED TAP.

TOTAL WT. = 40.873 lbmass

			THIS DOCUMENT CONTAINS PROPRIETARY INFORMATION. DUPLICATION OR DISCLOSURE IS PROHIBITED WITHOUT THE EXPRESSED WRITTEN CONSENT OF FABRICATED METALS LLC	TOLERANCES: UNLESS OTHERWISE SPECIFIED FRACTIONAL ±1/8" 2 PLACE DEC. ±.03 3 PLACE DEC. ±.005 ANGULAR ±1°	DRAWN BY: P. DAUGHERTY	<b>UTILITY METALS</b> (A DIVISION OF FABRICATED METALS LLC.) DESCRIPTION: <b>3 LIGHT @ 120° BULLHORN BRACKET TO SLIPFIT 3 1/2"</b>	PART NO. <b>S3-A24-3.5</b>			
					APPROVED: DL				DWG NO. <b>G-9390-0</b>	
					ECN:				REV <b>00</b>	
REV					DATE		BY	DESCRIPTION		