

2 3/8" O.D. x .154 WALL TB.

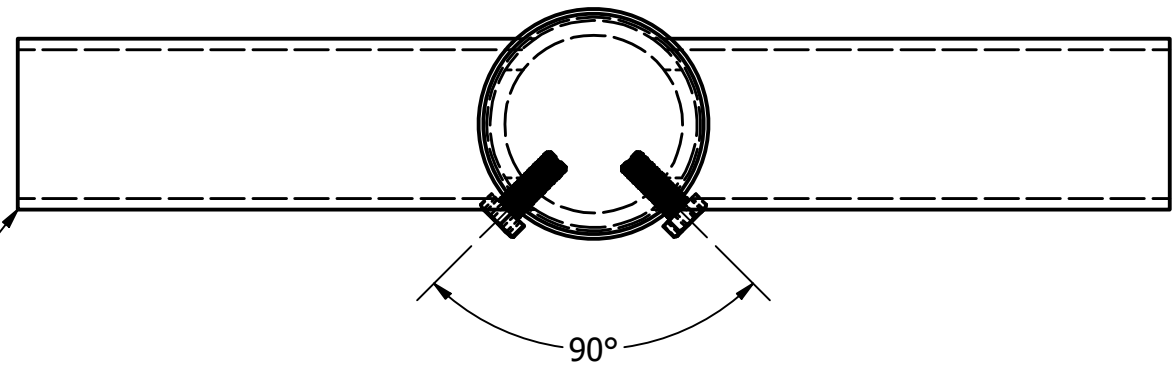

90°

DOME CAP

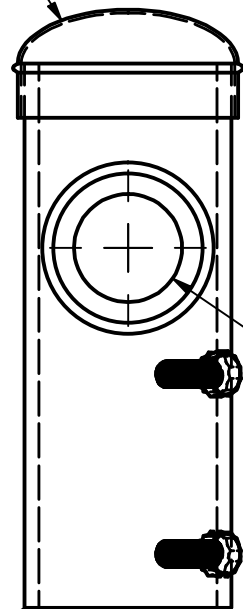

Ø1 1/2" (2 PLCS.)

2 7/8" O.D. x .203 WALL TB.

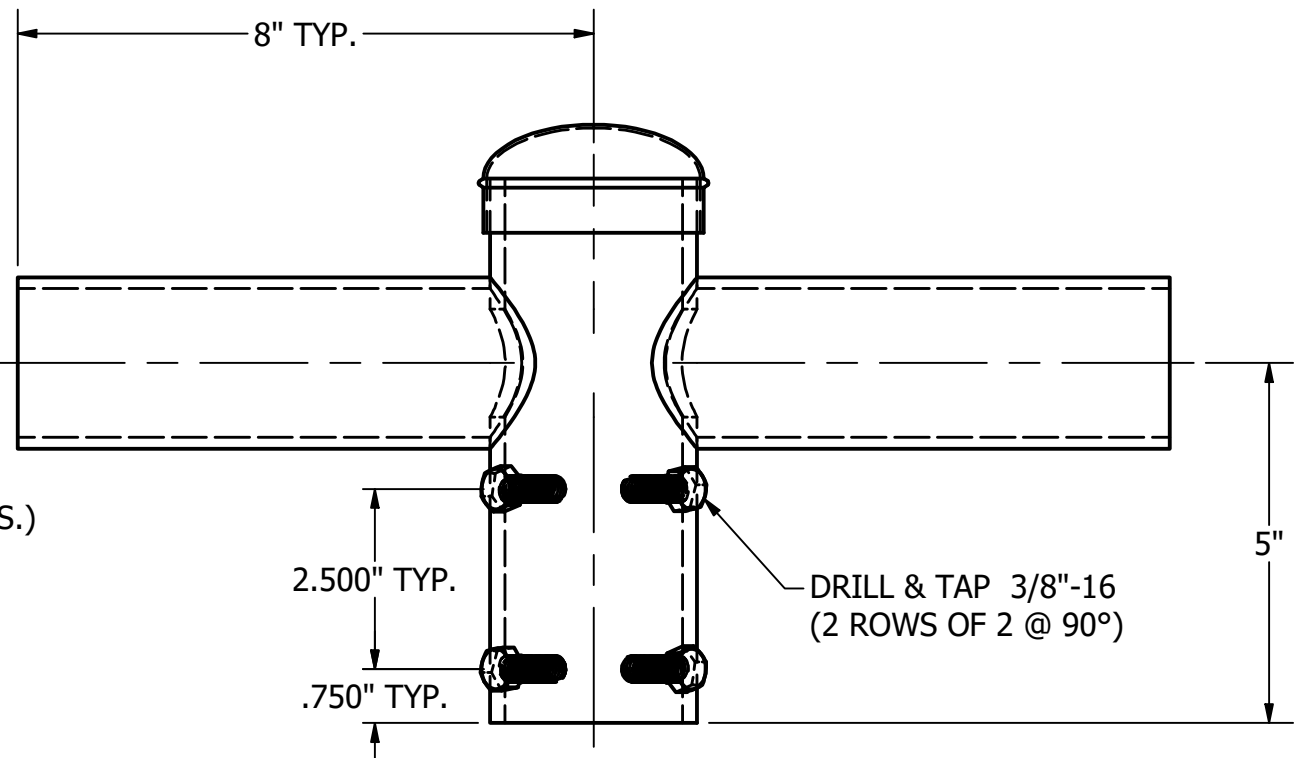

TOTAL WT. = 7.823 lbmass

BRACKET EPA = .6

			THIS DOCUMENT CONTAINS PROPRIETARY INFORMATION. DUPLICATION OR DISCLOSURE IS PROHIBITED WITHOUT THE EXPRESSED WRITTEN CONSENT OF FABRICATED METALS LLC	<b>TOLERANCES: UNLESS OTHERWISE SPECIFIED</b> FRACTIONAL ±1/8" 2 PLACE DEC. ±.03 3 PLACE DEC. ±.005 ANGULAR ± 1°	DRAWN BY: P. DAUGHERTY	<b>UTILITY METALS</b> (A DIVISION OF FABRICATED METALS LLC.) DESCRIPTION: 2" x 8" 2 @ 180° SPOKE BRACKET TO SLIP 2 3/8" TENON	PART NO. SB-218-08-2	
					APPROVED: PD		DWG NO. G-8272-0	
					ECN:		REV 0	
REV   DATE   BY   DESCRIPTION					SCALE: FULL		DATE: 5/24/2018	