

2 7/8" O.D. x .203 WALL TB.

1/4" PLATE

4" SCH. 80 PIPE

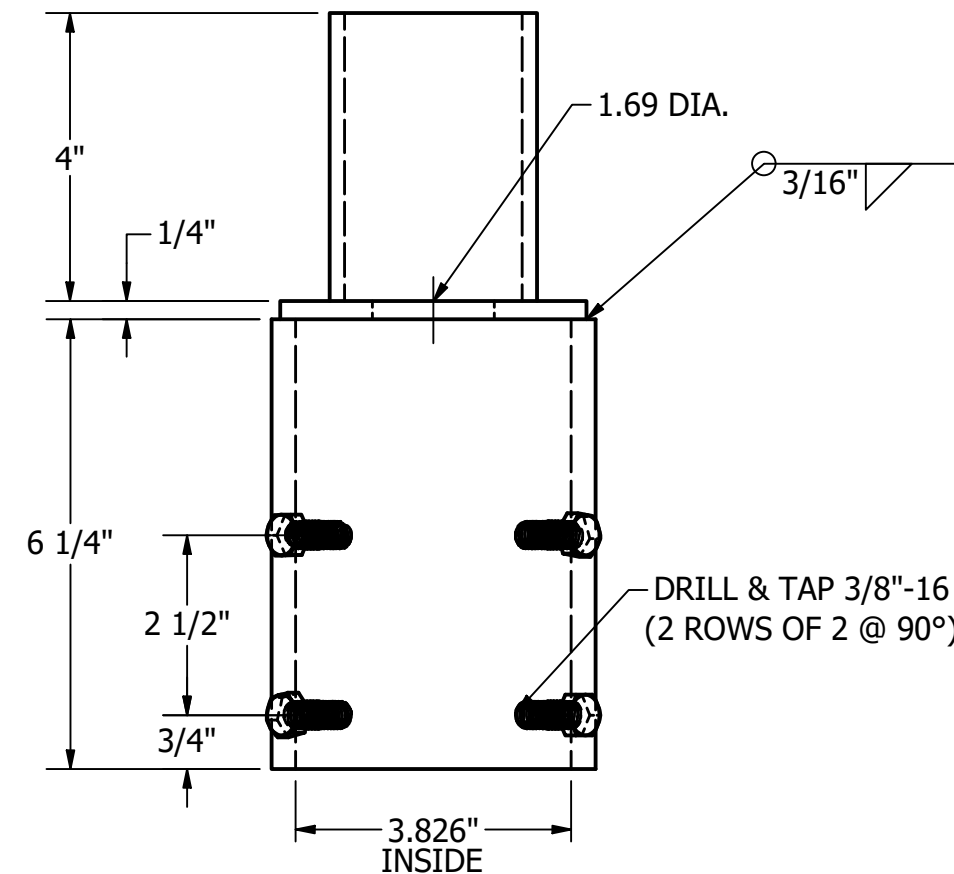
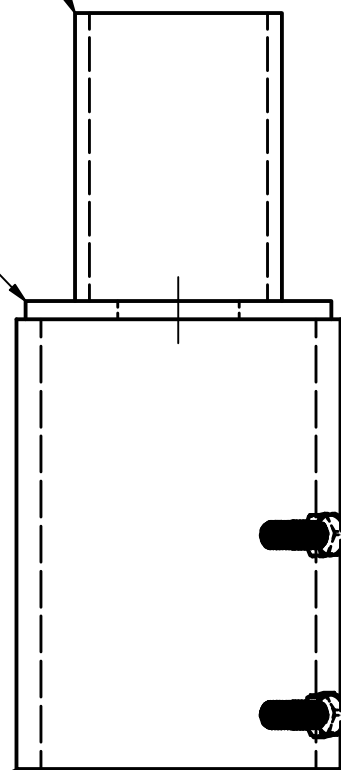

TOTAL WT. = 10.721 lbmass

			THIS DOCUMENT CONTAINS PROPRIETARY INFORMATION. DUPLICATION OR DISCLOSURE IS PROHIBITED WITHOUT THE EXPRESSED WRITTEN CONSENT OF FABRICATED METALS LLC	<b>TOLERANCES: UNLESS OTHERWISE SPECIFIED</b> FRACTIONAL ±1/8" 2 PLACE DEC. ±.03 3 PLACE DEC. ±.005 ANGULAR ±1°	DRAWN BY: P. DAUGHERTY	<b>UTILITY METALS</b> (A DIVISION OF FABRICATED METALS LLC.)	PART NO. TR-35-3		
					APPROVED: PD		DESCRIPTION: <b>3 1/2" TO 2 7/8" TENON REDUCER</b>	DWG NO. G-9433	
					ECN:			REV 0	
REV   DATE   BY   DESCRIPTION					SCALE: 3/8" = 1" DATE: 10/19/2020				