

3" SCH. 40 PIPE

1/4" PLATE

4 3/4" O.D. x 1/4" WALL TB.

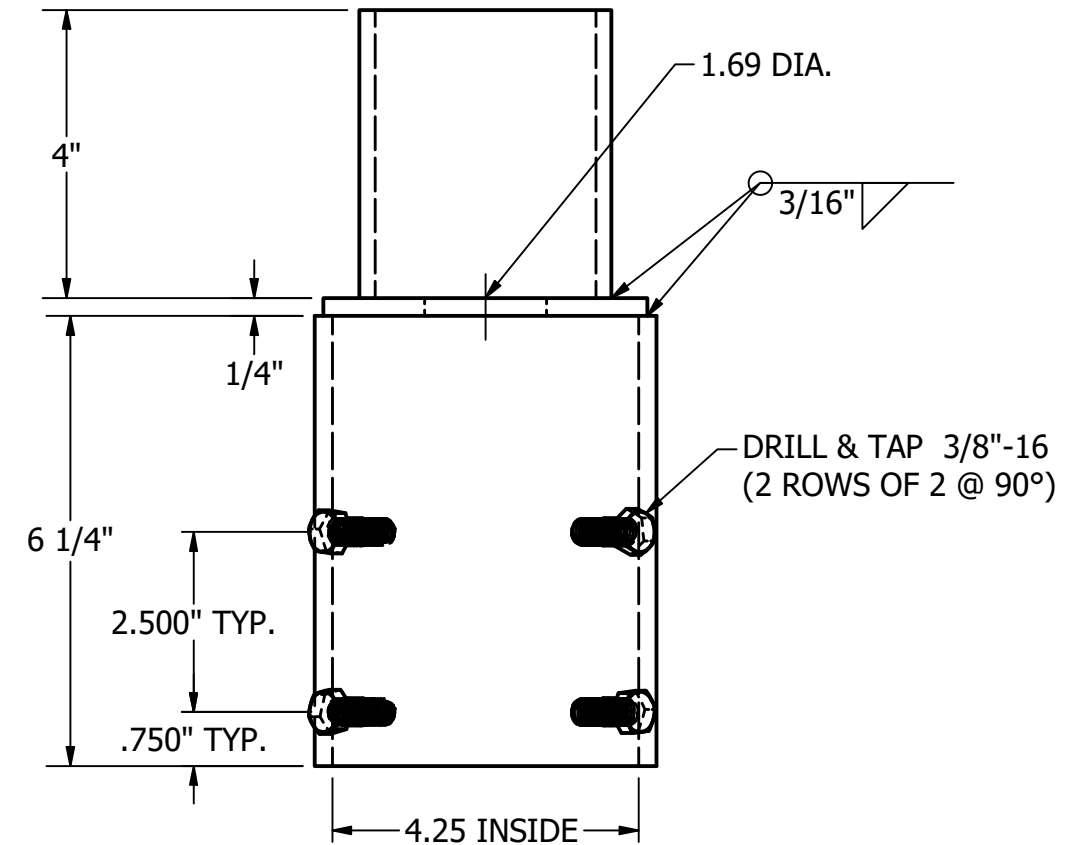

TOTAL WT. = 9.901 lbmass

			THIS DOCUMENT CONTAINS PROPRIETARY INFORMATION. DUPLICATION OR DISCLOSURE IS PROHIBITED WITHOUT THE EXPRESSED WRITTEN CONSENT OF FABRICATED METALS LLC	TOLERANCES: UNLESS OTHERWISE SPECIFIED FRACTIONAL ±1/8" 2 PLACE DEC. ±.03 3 PLACE DEC. ±.005 ANGULAR ±1°	DRAWN BY: P. DAUGHERTY	UTILITY METALS (A DIVISION OF FABRICATED METALS LLC.)	PART NO. TR-40-3.5		
					APPROVED: PD		DESCRIPTION: 4" TO 3 1/2" TENON REDUCER	DWG NO. G-9437-0	
					ECN:			REV 0	
REV DATE BY DESCRIPTION					SCALE: 3/8" = 1" DATE: 10/19/2020				