

TOTAL WT. = 10.542 lbmass

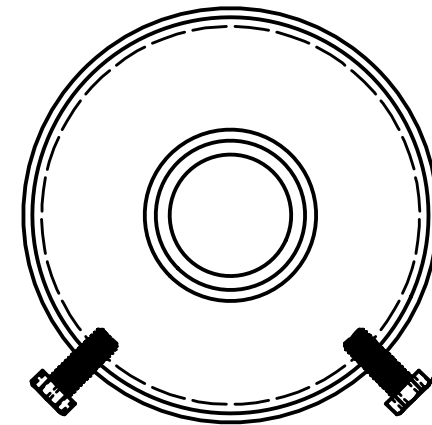

3/8"-16 X 1" HEX HEAD CAP SCREW  
(4 REQ'D)

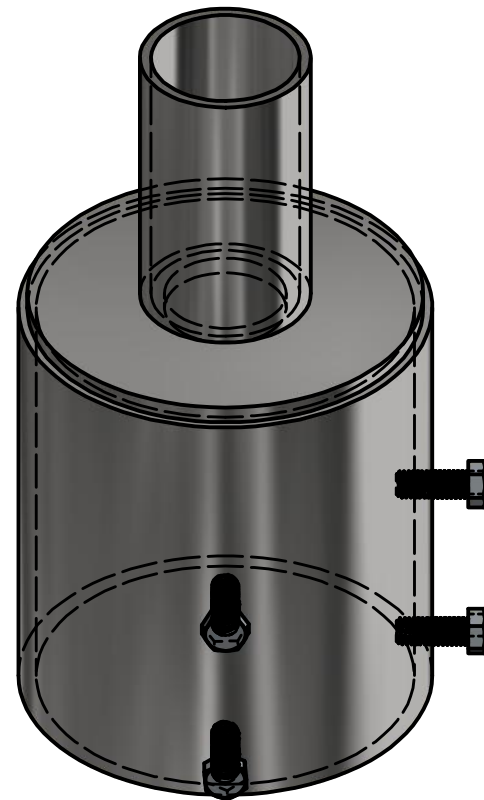
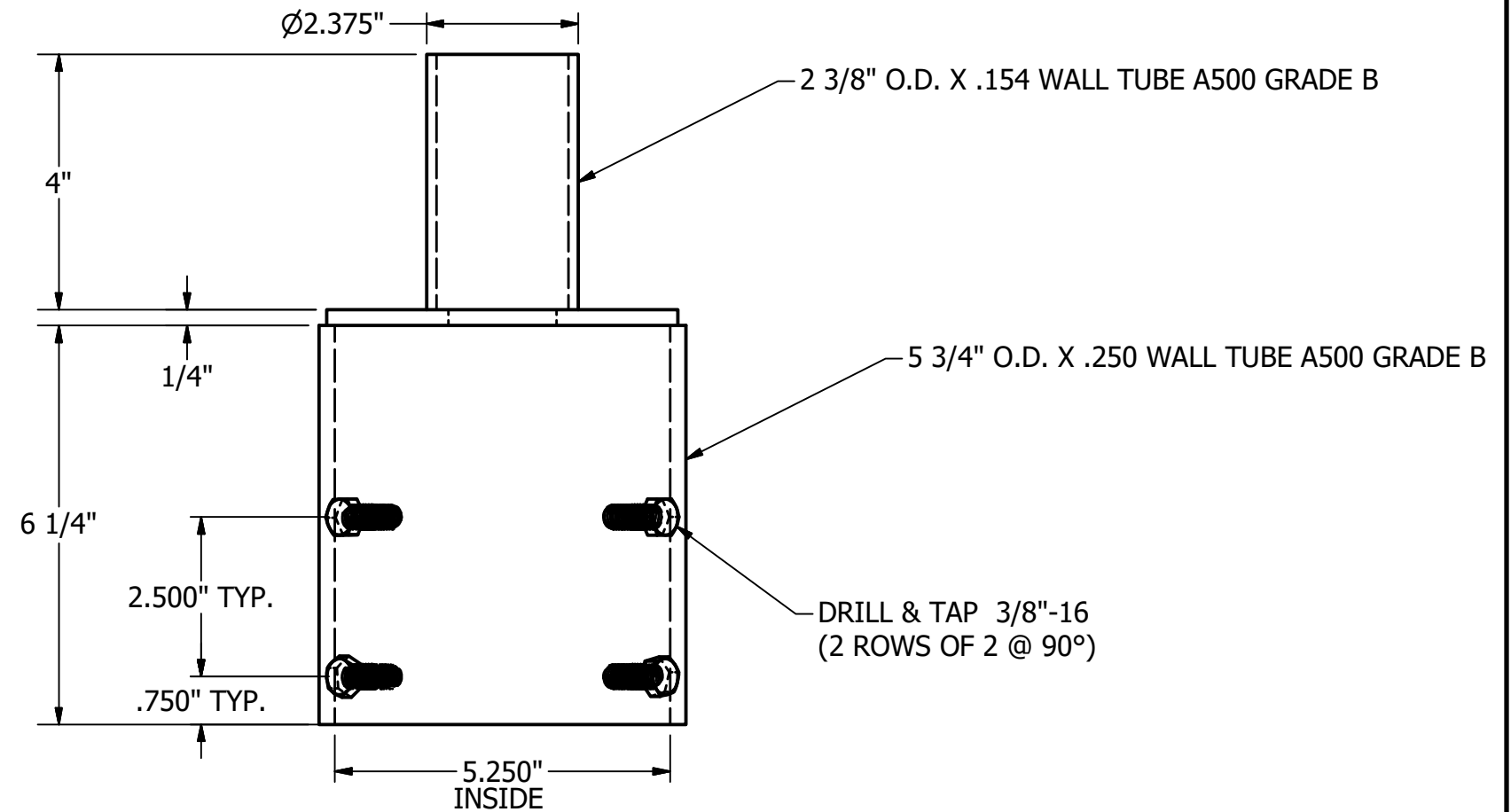

				THIS DOCUMENT CONTAINS PROPRIETARY INFORMATION. DUPLICATION OR DISCLOSURE IS PROHIBITED WITHOUT THE EXPRESSED WRITTEN CONSENT OF FABRICATED METALS LLC	TOLERANCES: UNLESS OTHERWISE SPECIFIED FRACTIONAL ±1/8" 2 PLACE DEC. ±.03 3 PLACE DEC. ±.005 ANGULAR ±1°	DRAWN BY: P. DAUGHERTY	UTILITY METALS (A DIVISION OF FABRICATED METALS LLC.)	PART NO. TR-50-2 BKT000127	
						APPROVED: PD		DESCRIPTION:	DWG NO. G-8113-0
						ECN:		5" TO 2 3/8" TENON REDUCER	
REV	DATE	BY	DESCRIPTION			SCALE: 3/8" = 1"			
						DATE: 2/7/2018			