

3/8" A36 PLATE

2 3/8" O.D. TUBE

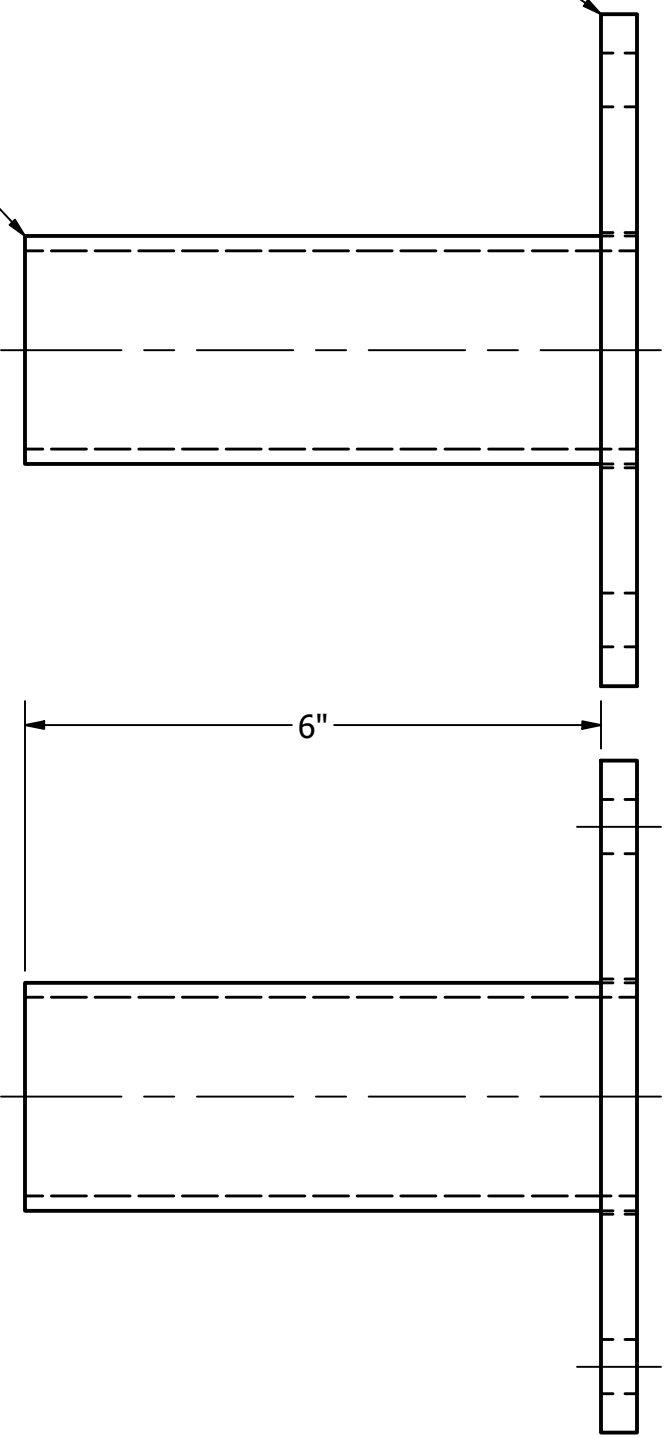
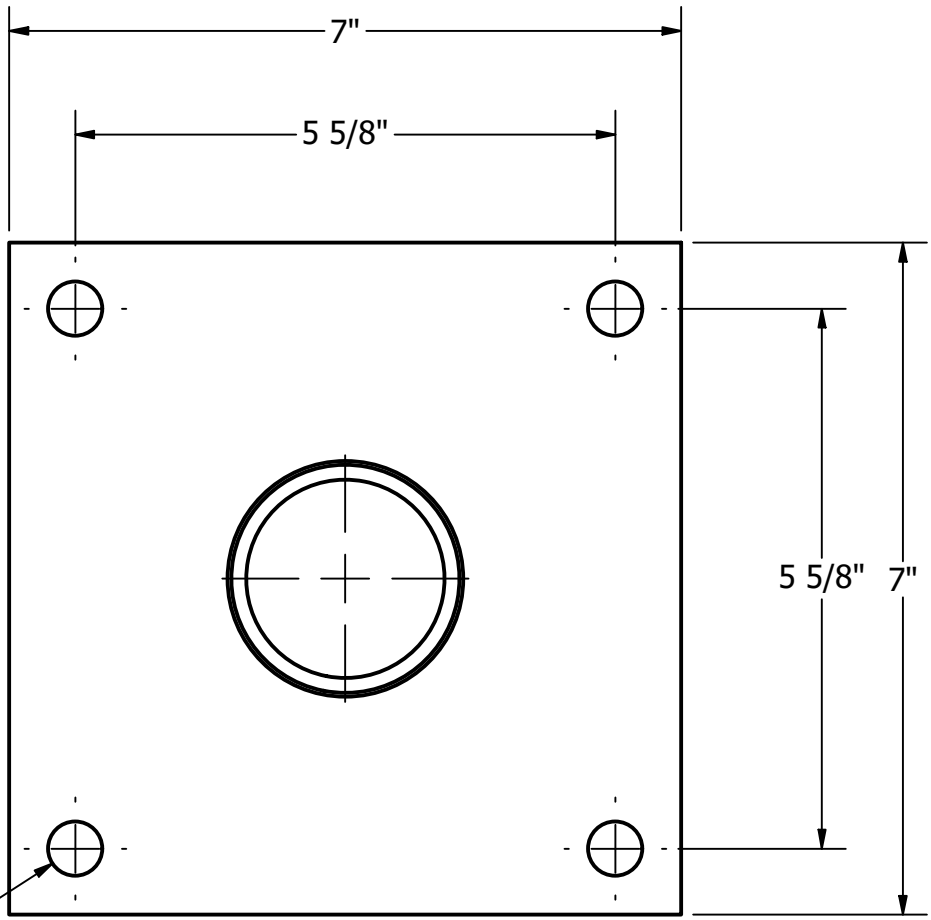

Ø.563" DIA. (4 PLCS.)

TOTAL WT. = 6.547 lbmass

REV	DATE	BY	DESCRIPTION

THIS DOCUMENT CONTAINS PROPRIETARY INFORMATION. DUPLICATION OR DISCLOSURE IS PROHIBITED WITHOUT THE EXPRESSED WRITTEN CONSENT OF FABRICATED METALS LLC

TOLERANCES: UNLESS OTHERWISE SPECIFIED
 FRACTIONAL ±1/8"
 2 PLACE DEC. ±.03
 3 PLACE DEC. ±.005
 ANGULAR ±1°

DRAWN BY: P. DAUGHERTY
 APPROVED: PD
 ECN:
 SCALE: 1/2" = 1"
 DATE: 2/20/2019

UTILITY METALS
 (A DIVISION OF FABRICATED METALS LLC.)

DESCRIPTION:
2" x 6" VERTICAL TENON

PART NO. **VT2-6**
BKT000111

DWG NO. **G-8674-0** REV **0**