

3/16" x 2 1/2" ALUM. FLAT BAR

8 9/16" REF.

1/4" x 1 1/2" ALUM. FLAT BAR

3/16"

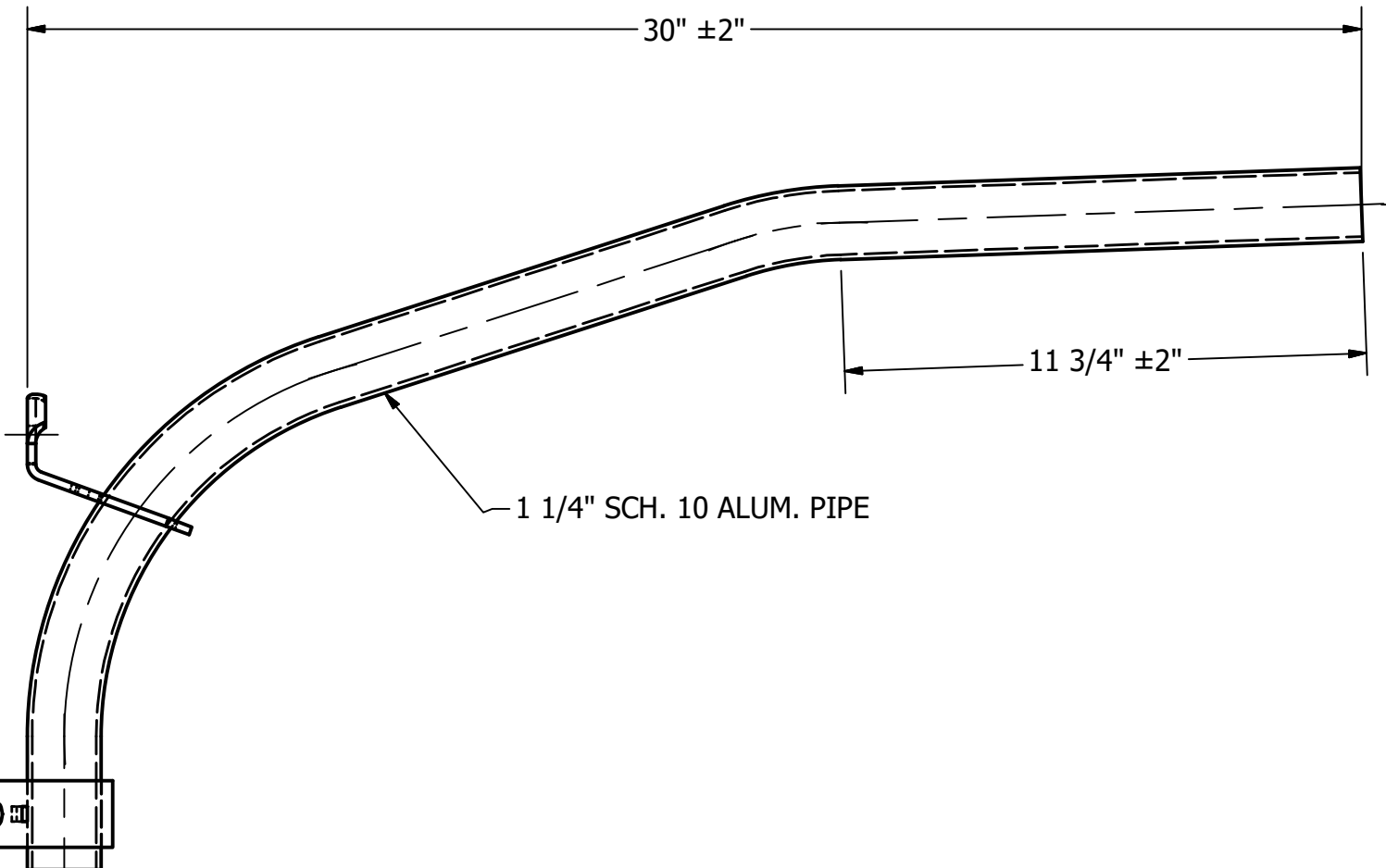

30" ±2"

11 3/4" ±2"

15" ±3"

1 1/4" SCH. 10 ALUM. PIPE

TOTAL WT. = 2.764 lbmass

REV	DATE	BY	DESCRIPTION

THIS DOCUMENT CONTAINS PROPRIETARY INFORMATION. DUPLICATION OR DISCLOSURE IS PROHIBITED WITHOUT THE EXPRESSED WRITTEN CONSENT OF FABRICATED METALS LLC

TOLERANCES: UNLESS OTHERWISE SPECIFIED

FRACTIONAL ±1/8"
2 PLACE DEC. ±.03
3 PLACE DEC. ±.005
ANGULAR ±1°

DRAWN BY: P. DAUGHERTY
APPROVED: PD
ECN:
SCALE: 1/4" = 1"
DATE: 1/29/2019

UTILITY METALS
(A DIVISION OF FABRICATED METALS LLC.)

DESCRIPTION:
1 1/4" x 30" ALUMINUM PLAIN BRACKET

PART NO.	M125A026
	MTA0000011
DWG NO.	F-8221-0
REV	0