

2 7/8" O.D. x .154 WALL TB.

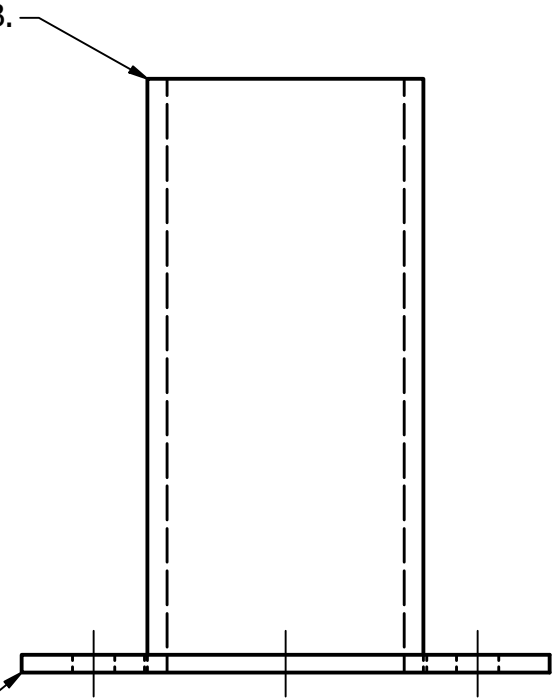

3/16" PLATE

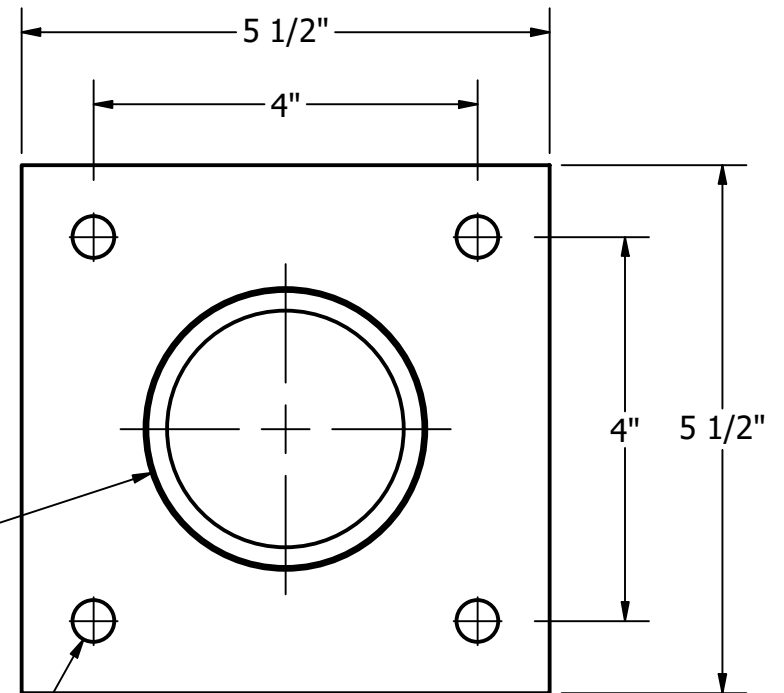
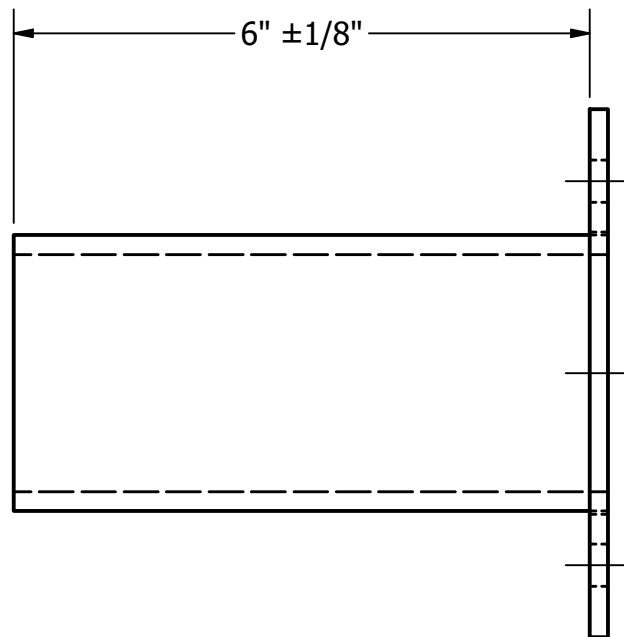

2.93 DIA.

.437 DIA. (4 PLCS.)

TOTAL WT. =4.206 lbmass

REV	DATE	BY	DESCRIPTION

THIS DOCUMENT CONTAINS PROPRIETARY INFORMATION. DUPLICATION OR DISCLOSURE IS PROHIBITED WITHOUT THE EXPRESSED WRITTEN CONSENT OF FABRICATED METALS LLC

TOLERANCES: UNLESS OTHERWISE SPECIFIED

FRACTIONAL ±1/8"  
2 PLACE DEC. ±.03  
3 PLACE DEC. ±.005  
ANGULAR ±1°

DRAWN BY: P. DAUGHERTY  
APPROVED: PD  
ECN:  
SCALE: 1/2" = 1"  
DATE: 11/12/2020

**UTILITY METALS**  
(A DIVISION OF FABRICATED METALS LLC.)  
DESCRIPTION:  
**3" x 6" TENON SLIPFITTER**

PART NO. **TTS-6**  
DWG NO. **G-9493-0** REV **0**