

JOB NAME			PART NO.		
DESCRIPTION:			DRAWING NO.		REV
DRAWN BY:	APPROVED:	ECN:	SCALE:	DATE:	

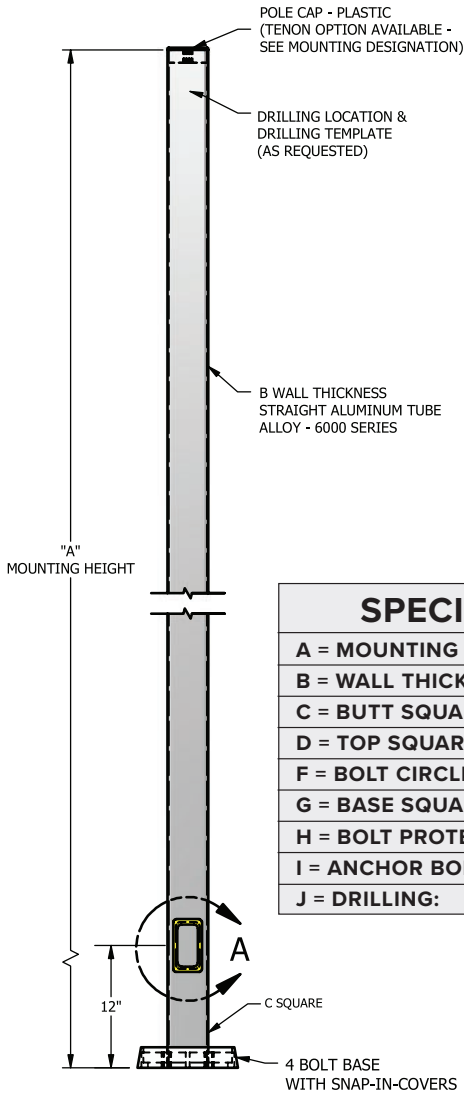

SPECIFICATIONS
<b>A = MOUNTING HEIGHT:</b>
<b>B = WALL THICKNESS: .188</b>
<b>C = BUTT SQUARE: 4"</b>
<b>D = TOP SQUARE: 4"</b>
<b>F = BOLT CIRCLE RANGE: 8.5" - 9.5"</b>
<b>G = BASE SQUARE: 9.938"</b>
<b>H = BOLT PROTECTION: 3.12"</b>
<b>I = ANCHOR BOLT SIZE: 3/4" X 20" X 3"</b>
<b>J = DRILLING:</b>

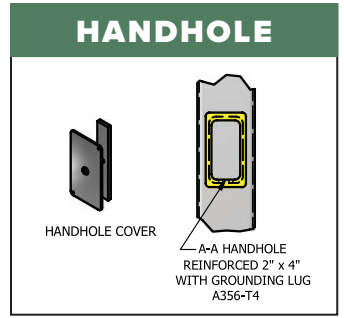
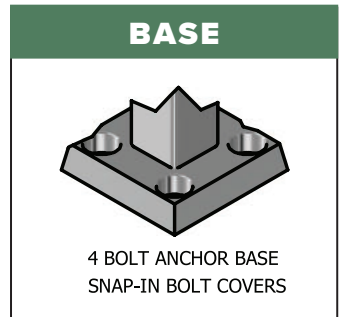
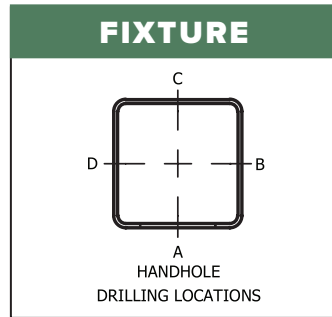
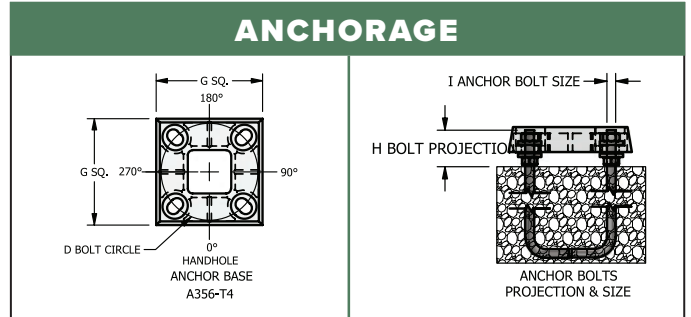

2013 AASHTO MAXIMUM EPA RATINGS WITH 3 SEC. WIND GUST								
ALUMINUM SQUARE STRAIGHT POLE SSA-4.0-0.188 SERIES								
PART NUMBER	MAX WT LBS	90 MPH SQ FT	100 MPH SQ FT	110 MPH SQ FT	120 MPH SQ FT	130 MPH SQ FT	140 MPH SQ FT	150 MPH SQ FT
SSA 4 188 8	350	32.60	25.80	21.20	17.60	14.80	12.60	10.80
SSA 4 188 10	260	25.70	20.50	16.50	13.50	11.20	9.40	7.80
SSA 4 188 12	260	20.70	16.20	13.00	10.60	8.60	7.10	5.80
SSA 4 188 14	200	17.00	13.10	10.40	8.30	6.60	5.30	4.30
SSA 4 188 16	200	16.00	10.70	8.30	6.40	5.00	3.80	2.90
SSA 4 188 18	150	11.30	8.50	6.40	4.80	3.60	2.60	1.80
SSA 4 188 20	150	9.10	6.80	5.00	3.60	2.50	1.60	0.88
SSA 4 188 24	150	6.20	4.10	2.60	1.50	0.60	NA	NA