

JOB NAME		PART NO.			
DESCRIPTION:		DRAWING NO.		REV	
DRAWN BY:	APPROVED:	ECN:	SCALE:	DATE:	

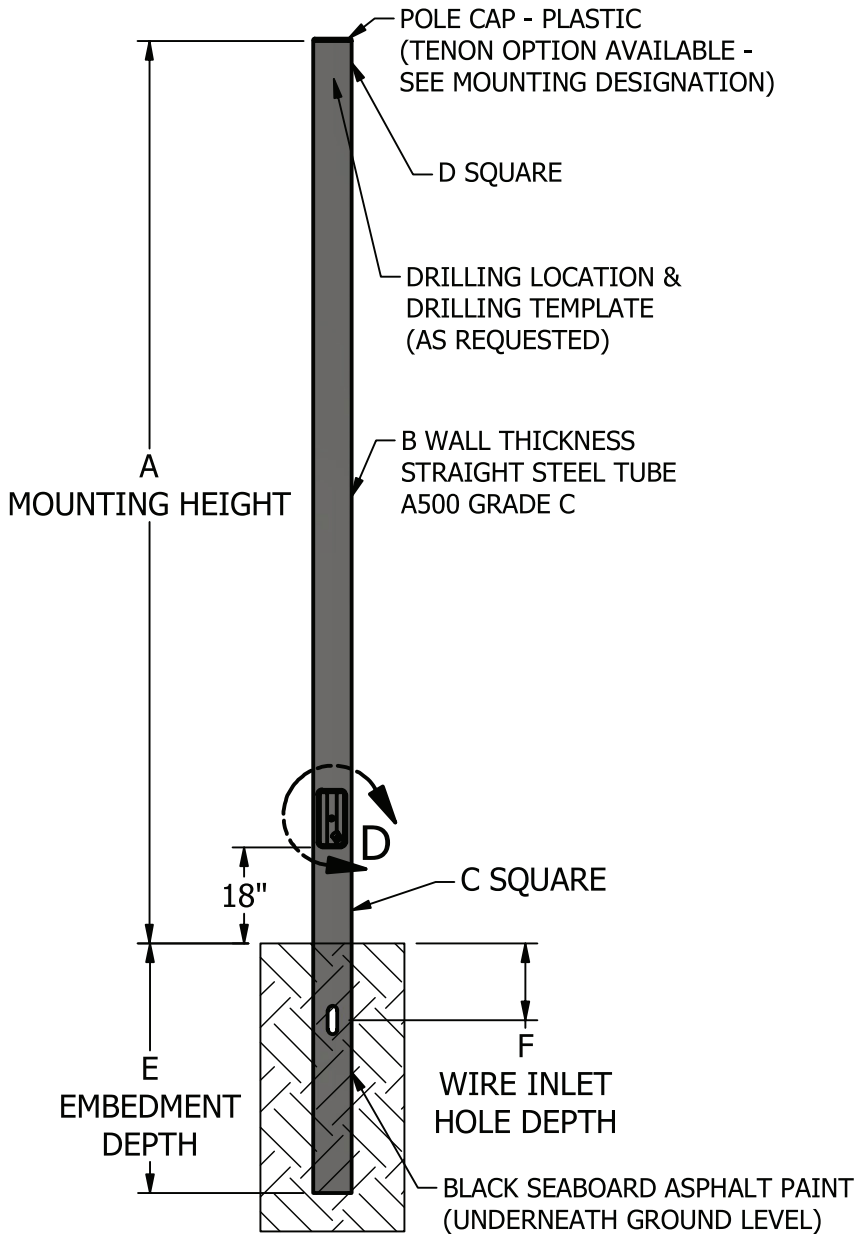

<b>SPECIFICATIONS</b>
<b>A = MOUNTING HEIGHT:</b>
<b>B = WALL THICKNESS: 7 GA.</b>
<b>C = BUTT SQUARE: 4"</b>
<b>D = TOP SQUARE: 4"</b>
<b>E = EMBEDMENT DEPTH: 2' +10%(A')</b>
<b>F = WIRE INLET HOLE DEPTH: E'/2</b>

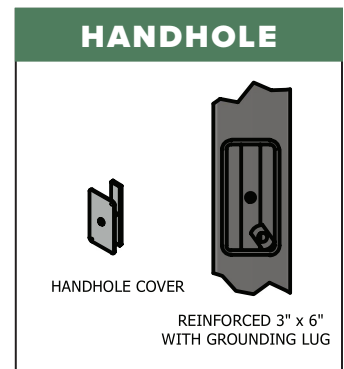
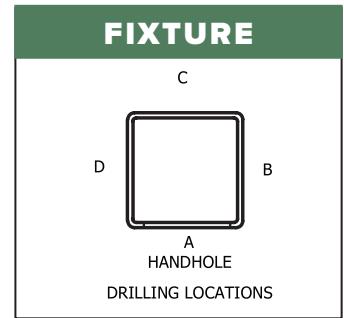

**2013 AASHTO MAXIMUM EPA RATINGS WITH 3 SEC. WIND GUST**

**DIRECT BURIAL STEEL SQUARE STRAIGHT POLE SSS 4 07 SERIES**

PART NUMBER	80 MPH SQ FT	90 MPH SQ FT	100 MPH SQ FT	110 MPH SQ FT	120 MPH SQ FT	130 MPH SQ FT	140 MPH SQ FT
DBSSS 4 07 20	25.93	19.53	14.96	11.57	9.00	7.00	4.12
DBSSS 4 07 25	17.03	12.31	8.94	6.44	4.54	3.06	0.94
DBSSS 4 07 30	11.61	7.76	5.00	2.96	1.14	0.21	NA