

JOB NAME		PART NO.		
DESCRIPTION:		DRAWING NO.		REV
DRAWN BY:	APPROVED:	ECN:	SCALE:	DATE:

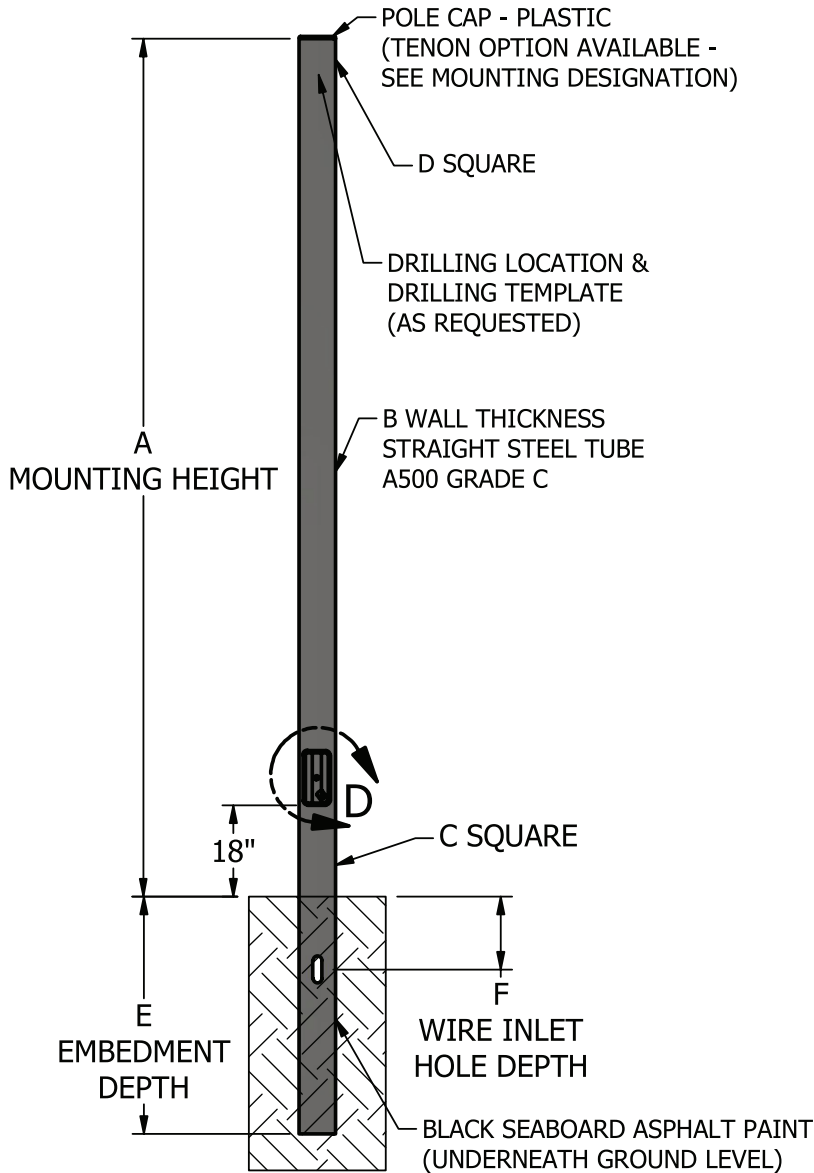

## SPECIFICATIONS

- A = MOUNTING HEIGHT:**
- B = WALL THICKNESS: 7 GA.**
- C = BUTT SQUARE: 6"**
- D = TOP SQUARE 6"**
- E = EMBEDMENT DEPTH: 2' +10%(A')**
- F = WIRE INLET HOLE DEPTH: E'/2**

### FIXTURE

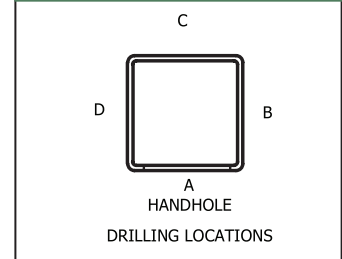

### HANDHOLE

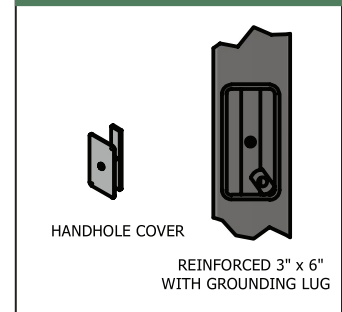

### 2013 AASHTO MAXIMUM EPA RATINGS WITH 3 SEC. WIND GUST

#### DIRECT BURIAL STEEL SQUARE STRAIGHT POLE DBSSS 6 07 SERIES

PART NUMBER	MAX WT LBS	90 MPH SQ FT	100 MPH SQ FT	110 MPH SQ FT	120 MPH SQ FT	130 MPH SQ FT	140 MPH SQ FT	150 MPH SQ FT
DBSSS 6 07 20	200	43.77	34.05	26.86	21.39	17.13	13.75	11.03
DBSSS 6 07 25	200	29.36	22.10	16.72	12.63	9.45	6.92	4.89
DBSSS 6 07 30	200	20.57	14.58	10.14	6.77	4.14	2.06	0.38
DBSSS 6 07 35	200	12.91	8.08	4.51	1.79	N/A	N/A	N/A
DBSSS 6 07 40	200	7.24	3.09	0.02	N/A	N/A	N/A	N/A