

JOB NAME			PART NO.		
DESCRIPTION:			DRAWING NO.		REV
DRAWN BY:	APPROVED:	ECN:	SCALE:	DATE:	

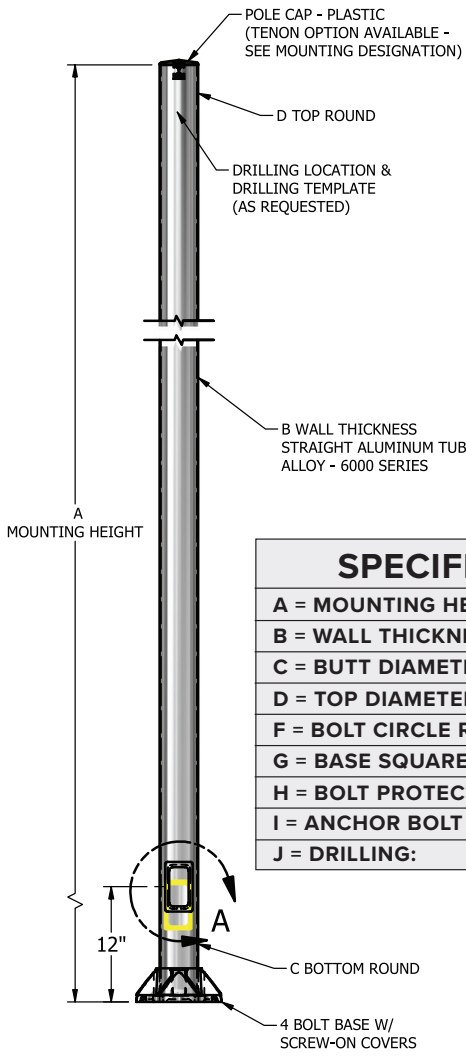

SPECIFICATIONS
A = MOUNTING HEIGHT:
B = WALL THICKNESS: .125
C = BUTT DIAMETER: 5"
D = TOP DIAMETER: 5"
F = BOLT CIRCLE RANGE: 7.5" - 9.5"
G = BASE SQUARE: 9.0"
H = BOLT PROTECTION: 3 1/2"
I = ANCHOR BOLT SIZE: 3/4" X 20" X 3"
J = DRILLING:

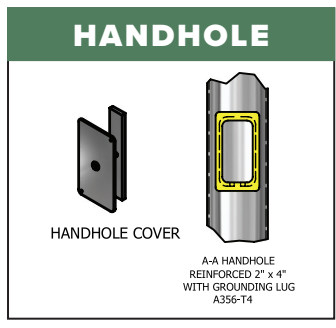
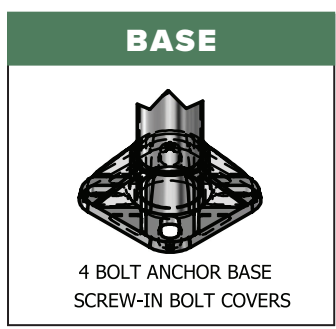
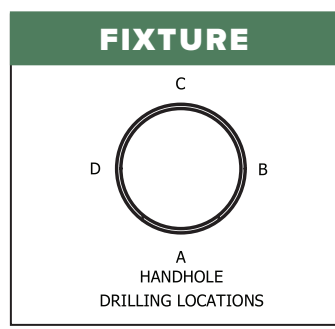
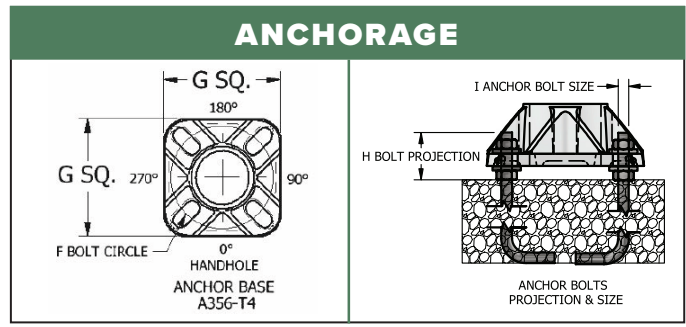

2013 AASHTO MAXIMUM EPA RATINGS WITH 3 SEC. WIND GUST
ALUMINUM ROUND STRAIGHT POLE RSA-5.0-0.125 SERIES

PART NUMBER	MAX WT LBS	90 MPH SQ FT	100 MPH SQ FT	110 MPH SQ FT	120 MPH SQ FT	130 MPH SQ FT	140 MPH SQ FT	150 MPH SQ FT
RSA 5 125 8	100	18.80	15.20	12.40	10.40	8.80	7.50	6.50
RSA 5 125 10	100	14.40	11.60	9.40	7.80	6.50	5.60	4.80
RSA 5 125 12	100	11.20	8.80	7.10	5.80	4.90	4.10	3.50
RSA 5 125 14	100	8.60	6.80	5.40	4.40	3.60	3.00	2.50
RSA 5 125 16	100	6.70	5.10	4.00	3.20	2.60	2.10	1.70
RSA 5 125 18	150	5.10	3.60	2.80	2.20	1.70	1.30	1.10
RSA 5 125 20	150	3.60	2.10	1.80	1.30	0.90	0.70	0.50
RSA 5 125 24	150	1.10	0.60	0.20	NA	NA	NA	NA
RSA 5 125 25	150	0.60	0.15	NA	NA	NA	NA	NA