

JOB NAME:		PART NO. SB-312-__-__	
DESCRIPTION: 2" 3 @ 120° SPOKE BRACKET FOR TENON		DRAWING NO.	REV 0
DRAWN BY: R.R.	APPROVED: P. A. D.	ECN:	SCALE: 1/8" = 1"      DATE: 10-28-24

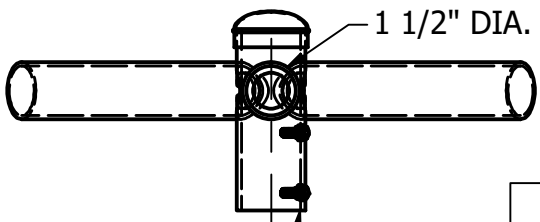

A500 GRADE B TB.

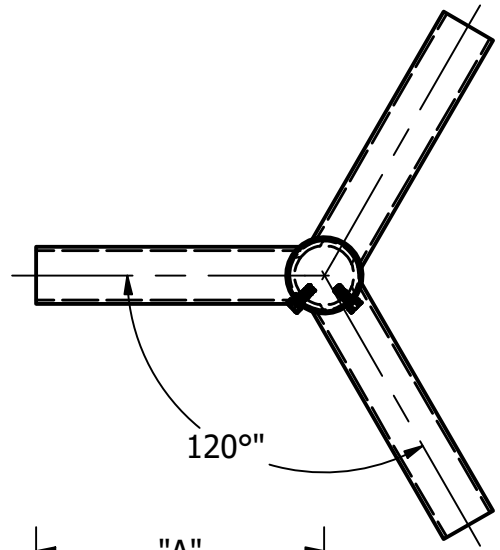
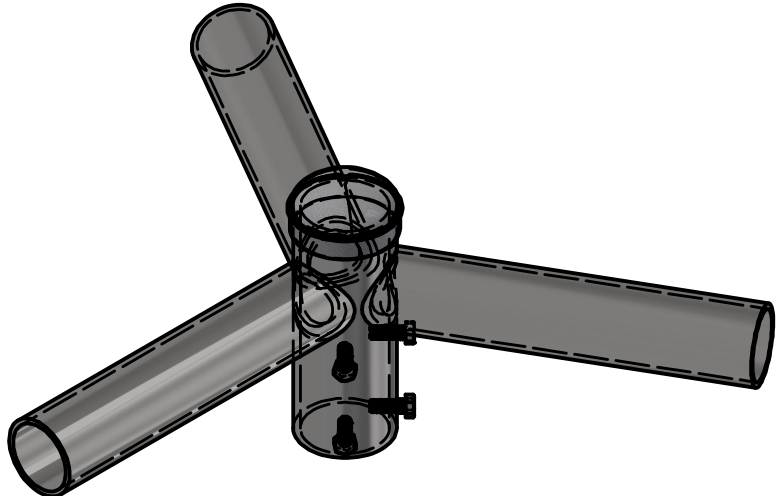
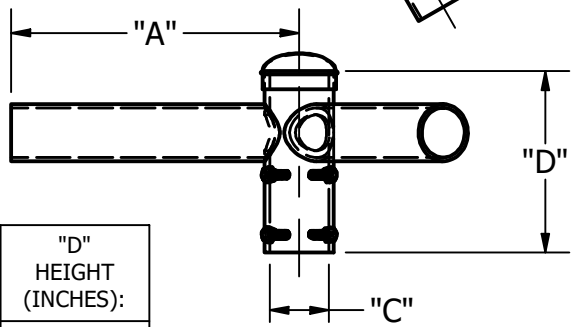

DESIGNED FOR TENON SIZE (INCHES):	"C" INSIDE DIA. (INCHES):	"D" HEIGHT (INCHES):
2-3/8"	2-15/32"	7-9/16"
2-7/8"	3-1/16"	8-9/16"
4"	4 1/4"	9"

\*Data usable on pole up to 50 ft.

"A" ARM LENGTH (INCHES):	BRACKET EPA (FT^2):	TOTAL WEIGHT (lbs.):	BRACKET LOADING DATA:					
			100 MPH		120 MPH		150 MPH	
			MAX FIXTURE WEIGHT (lbs.):	MAX EPA (FT^2) PER FIXTURE:	MAX FIXTURE WEIGHT (lbs.):	MAX EPA (FT^2) PER FIXTURE:	MAX FIXTURE WEIGHT (lbs.):	MAX EPA (FT^2) PER FIXTURE:
8	0.6	11	85	8	85	8	85	6.6
12	0.8	15	85	8	85	8	85	6.6
15	0.9	17	85	8	85	8	85	6.6
24	1.4	25	85	8	85	8	85	6.3
30	1.7	30	85	8	85	6.5	85	4.2
36	2.1	36	85	8	45	4.9	45	3.1