

JOB NAME		PART NO. G-10643-01 DBRSA-4.5-188 SPEC-SHEET.idw	
DESCRIPTION:		DRAWING NO. G-10643-01	REV 01
DRAWN BY: R. REDMON	APPROVED: RR	ECN:	SCALE: 1/16" DATE: 5/12/2026

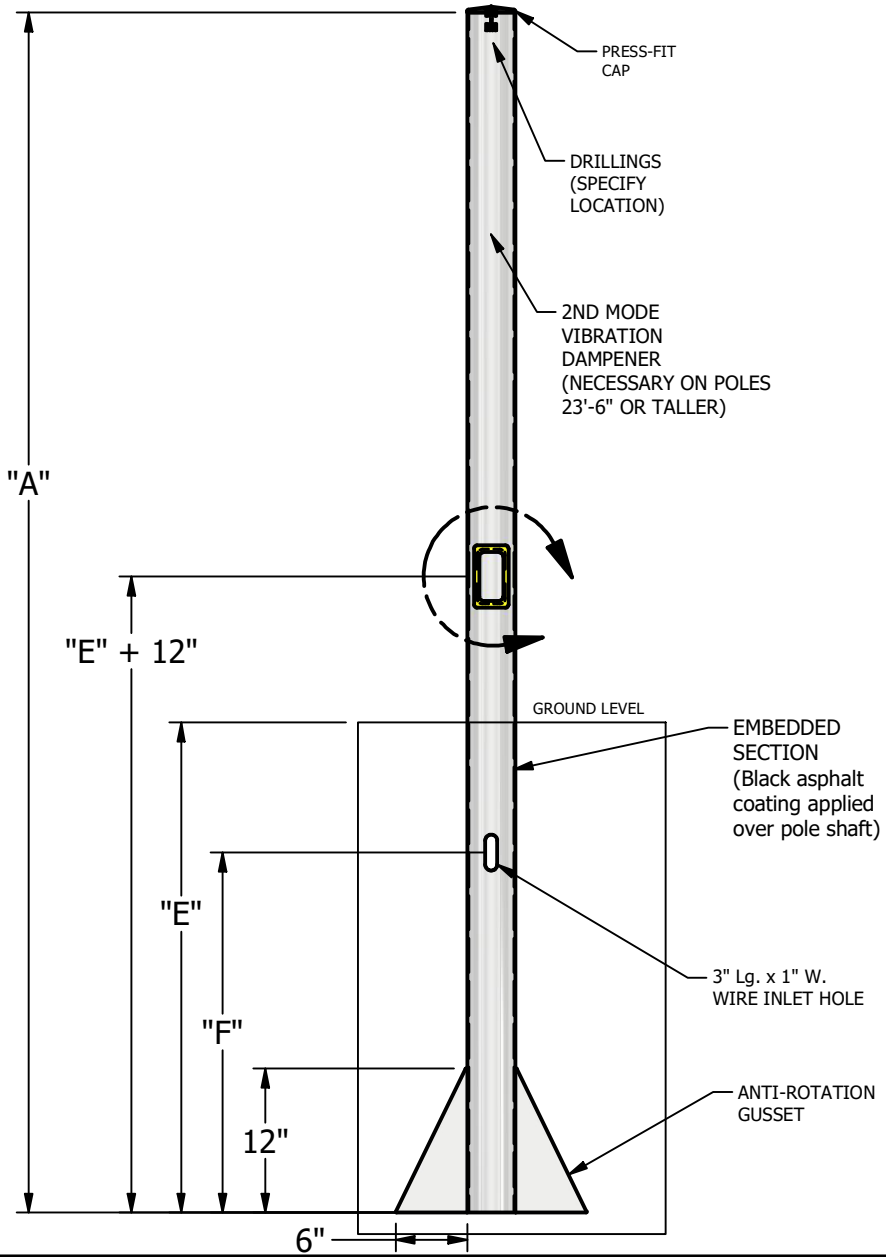

SPECIFICATIONS
A = MOUNTING HEIGHT:
B = WALL THICKNESS: 0.188"
C = BUTT ROUND: 4.5"
D = TOP ROUND: 4.5"
E = EMBEDDED DEPTH = 10%(A) + 2'
F = WIRE INLET HOLE = E/2

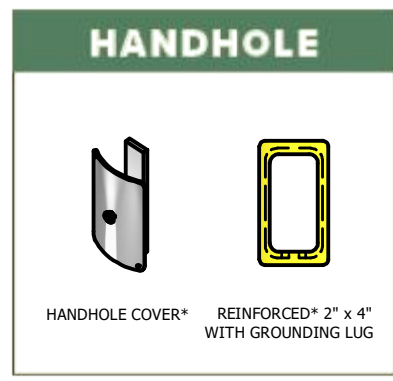
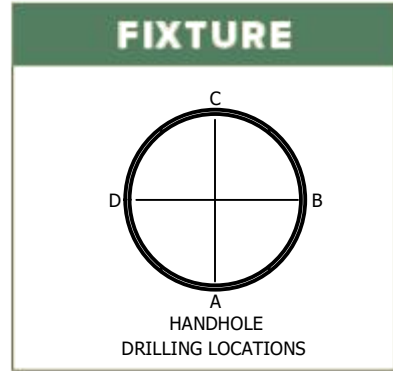

2013 AASHTO WITH 3 SEC. WIND GUST

**DIRECT BURIAL ROUND STRAIGHT ALUMINUM POLE DBRSA-4.5-.188 SERIES**

PART NUMBER	MAX WT LBS	90 MPH SQ FT	100 MPH SQ FT	110 MPH SQ FT	120 MPH SQ FT	130 MPH SQ FT	140 MPH SQ FT	150 MPH SQ FT
DBRSA-4.5-0.188-8	100	23.00	18.20	14.80	12.50	10.50	9.10	7.80
DBRSA-4.5-0.188-10	100	17.60	13.70	11.20	9.30	7.80	6.70	5.80
DBRSA-4.5-0.188-12	100	14.00	10.90	8.60	7.20	6.00	5.10	4.40
DBRSA-4.5-0.188-14	100	11.10	8.50	6.70	5.50	4.60	3.80	3.30
DBRSA-4.5-0.188-16	100	9.00	6.60	5.10	4.00	3.40	2.80	2.20
DBRSA-4.5-0.188-18	150	7.00	4.90	3.70	3.00	2.40	1.90	1.60
DBRSA-4.5-0.188-20	150	5.40	3.60	2.60	2.00	1.50	1.20	0.95