

JOB NAME		PART NO. G-11783-0 DBRSA-6-188 SPEC-SHEET.idw	
DESCRIPTION:		DRAWING NO. G-11783-0	REV 0
DRAWN BY: R. REDMON	APPROVED: RR	ECN:	SCALE: 1/16" DATE: 5/12/2026

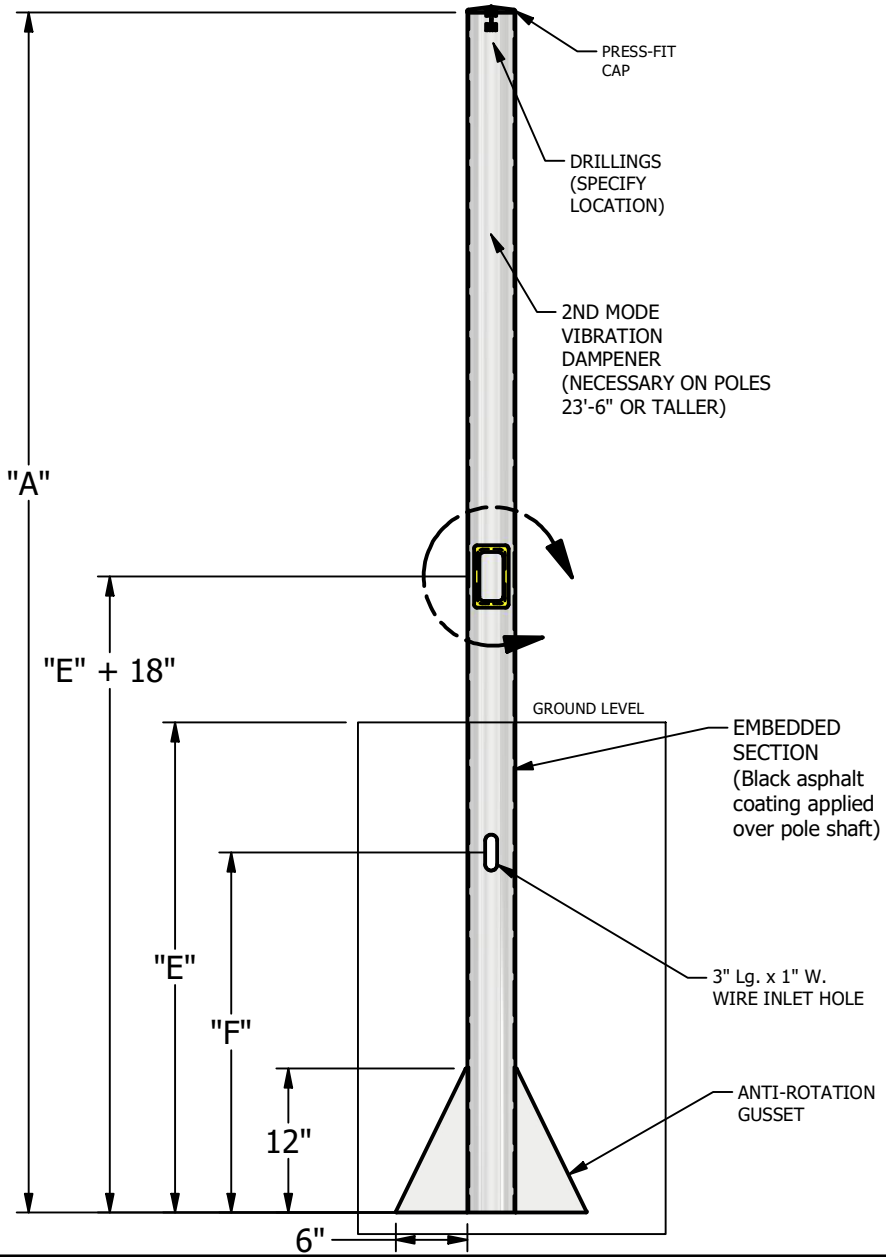

SPECIFICATIONS
A = MOUNTING HEIGHT:
B = WALL THICKNESS: 0.188"
C = BUTT ROUND: 6"
D = TOP ROUND: 6"
E = EMBEDDED DEPTH = 10%(A) + 2'
F = WIRE INLET HOLE = E/2

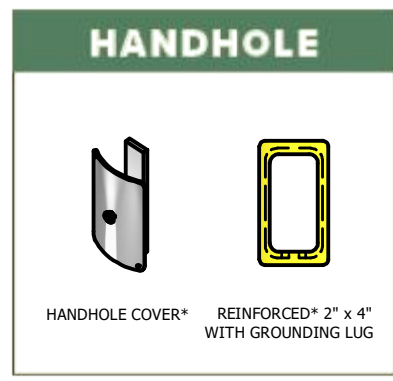
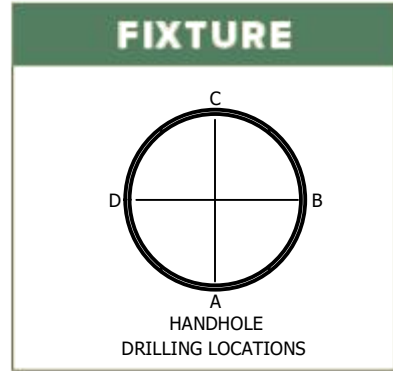

2013 AASHTO WITH 3 SEC. WIND GUST

DIRECT BURIAL ROUND STRAIGHT ALUMINUM POLE DBRSA-6-.156 SERIES

PART NUMBER	MAX WT LBS	90 MPH SQ FT	100 MPH SQ FT	110 MPH SQ FT	120 MPH SQ FT	130 MPH SQ FT	140 MPH SQ FT	150 MPH SQ FT
DBRSA-6-0.188-8	350	53.20	42.60	35.80	30.70	25.50	22.00	19.00
DBRSA-6-0.188-10	260	42.10	33.70	27.90	23.40	20.00	16.90	14.80
DBRSA-6-0.188-12	260	34.00	27.60	22.80	18.90	16.00	13.70	11.80
DBRSA-6-0.188-14	200	28.80	22.50	19.00	15.80	13.30	11.40	9.80
DBRSA-6-0.188-16	200	24.10	19.30	15.80	13.00	11.00	9.40	8.10
DBRSA-6-0.188-18	150	20.00	15.80	12.90	10.70	9.10	7.70	6.60
DBRSA-6-0.188-20	150	16.80	13.30	10.80	8.90	7.50	6.30	5.30