

2 3/8" O.D. x .154 WALL TB.

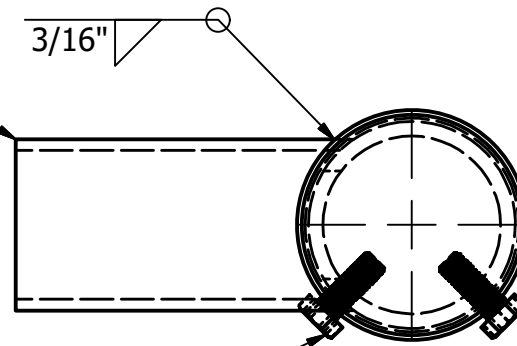

DRILL & TAP 3/8"-16
(2 ROWS OF 2 @ 90°)

DOME CAP

1 1/2" DIA.

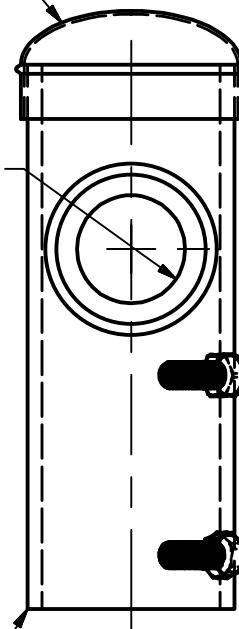

2 7/8" O.D. x .203 WALL TB.

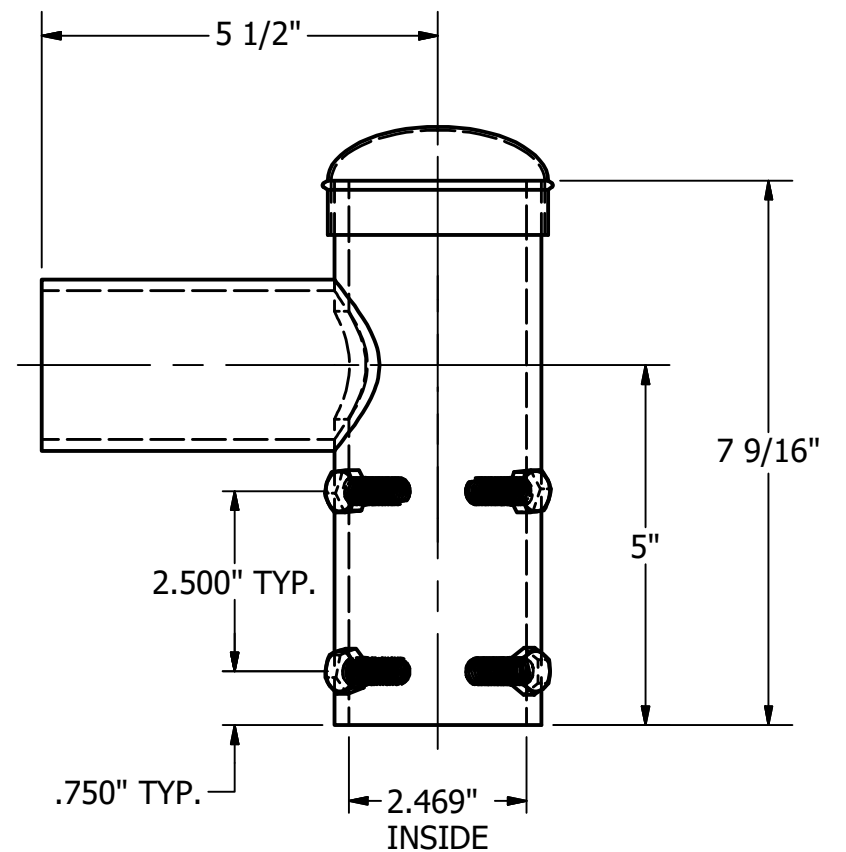

NOTE: FOR GALVANIZED BRACKETS ONLY DRILL
& TAP 3/8"-16 .010 OVERSIZED TAP.

TOTAL WT. = 5.092 lbmass
BRACKET EPA = .3

			THIS DOCUMENT CONTAINS PROPRIETARY INFORMATION. DUPLICATION OR DISCLOSURE IS PROHIBITED WITHOUT THE EXPRESSED WRITTEN CONSENT OF FABRICATED METALS LLC	TOLERANCES: UNLESS OTHERWISE SPECIFIED FRACTIONAL ±1/8" 2 PLACE DEC. ±.03 3 PLACE DEC. ±.005 ANGULAR ±1°	DRAWN BY: P. DAUGHERTY	UTILITY METALS (A DIVISION OF FABRICATED METALS LLC.) DESCRIPTION: 2" x 5 1/2" SINGLE SPOKE BRACKET FOR 2 3/8" TENON	PART NO.	
					APPROVED: PD		SB-100-5.5-2	
					ECN:		DWG NO.	
REV	DATE	BY			SCALE: 3/8" = 1"		G-9400-0	
			DATE: 9/28/2020	REV				
				0				