

2 3/8" O.D. x .154 WALL TB.

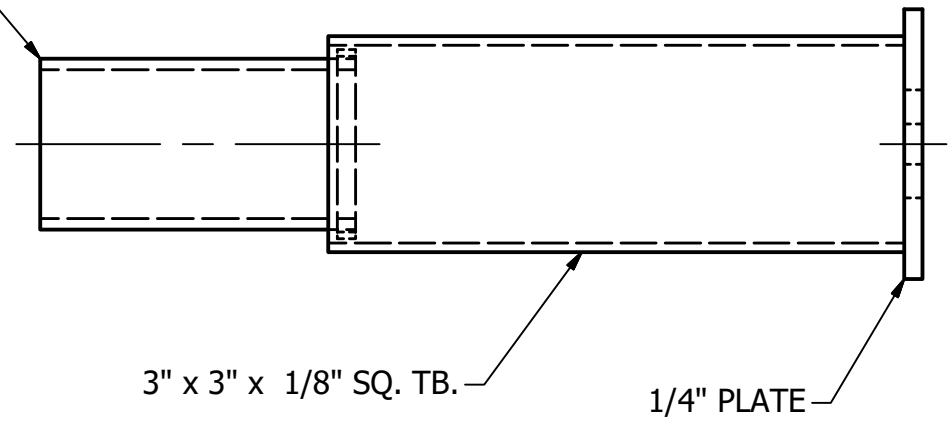

3" x 3" x 1/8" SQ. TB.

1/4" PLATE

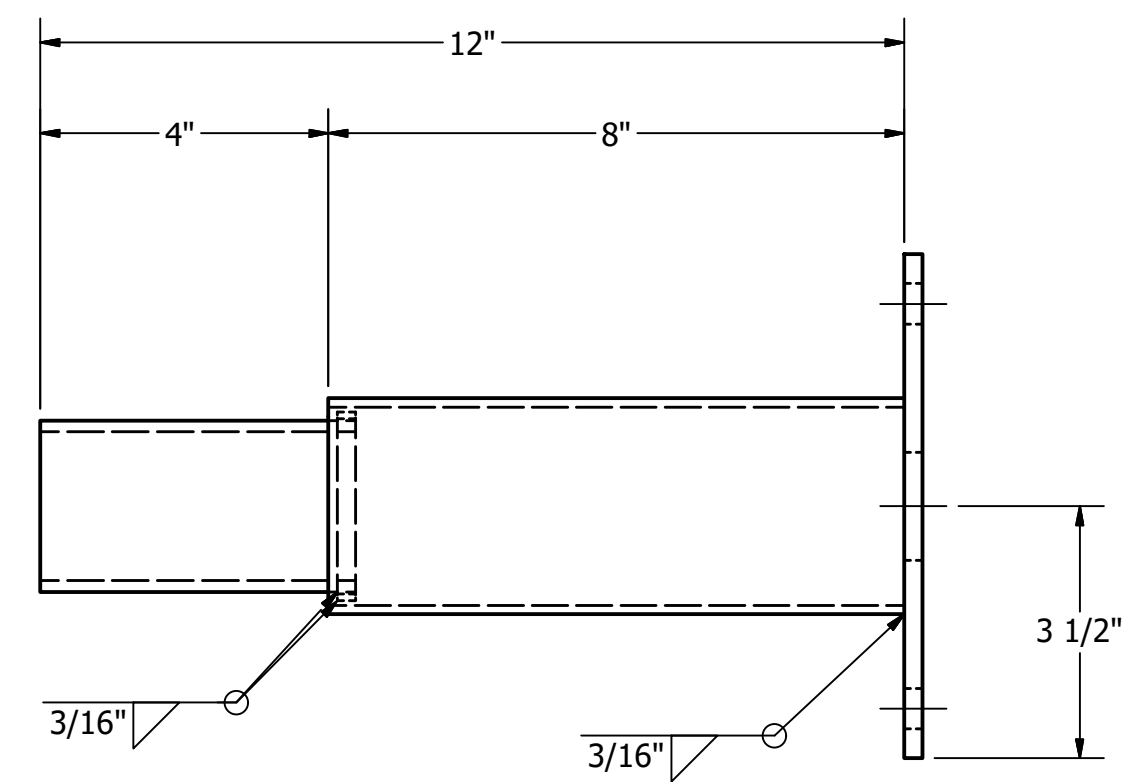
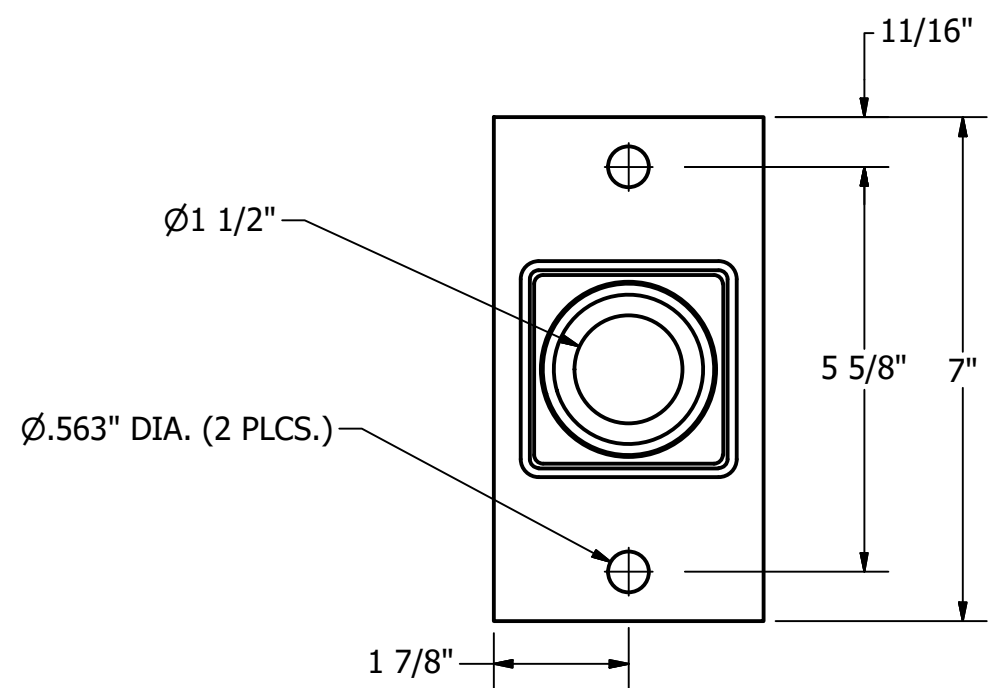

TOTAL WT. = 6.361 lbmass

				THIS DOCUMENT CONTAINS PROPRIETARY INFORMATION. DUPLICATION OR DISCLOSURE IS PROHIBITED WITHOUT THE EXPRESSED WRITTEN CONSENT OF FABRICATED METALS LLC	TOLERANCES: UNLESS OTHERWISE SPECIFIED FRACTIONAL ±1/8" 2 PLACE DEC. ±.03 3 PLACE DEC. ±.005 ANGULAR ±1°	DRAWN BY: P. DAUGHERTY	<b>UTILITY METALS</b> (A DIVISION OF FABRICATED METALS LLC.)	PART NO. <b>SMBE-6.5</b>		
						APPROVED: PD		DESCRIPTION: <b>6 1/2" SIDE MOUNT BRACKET - END</b>	DWG NO. <b>G-9373-0</b>	
						ECN:			REV <b>0</b>	
						SCALE: 3/8" = 1" DATE: 9/10/2020				
REV	DATE	BY	DESCRIPTION							